

CHARLESTON TOWN

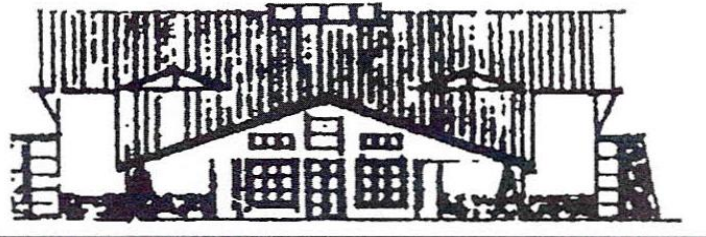

THE LAND USE ORDINANCE OF CHARLESTON TOWN, UTAH

Amended Ordinance # 2021-01

Amended Ordinance # 2024-02

Updated December 2024

CHARLESTON TOWN

CHARLESTON TOWN LAND USE & ZONING ORDINANCE
TABLE OF CONTENTS

02.0100 TITLE, INTENT, AND PURPOSE.....10

02.0200 APPLICATION10

02.0300 DECLARATION10

02.0400 INTERPRETATION.....10

02.0500 DEFINITIONS.....11

 02.0501 Intent11

 02.0502 Agriculture11

 02.0503 Boarding House -- Lodging House11

 02.0504 Building.....11

 02.0505 Caretaker Dwelling11

 02.0506 Carport11

 02.0507 Clinic.....11

 02.0508 Club.....12

 02.0509 Common Area.....12

 02.0510 Conditional Use12

 02.0511 Convenience Establishments12

 02.0512 Convalescent Home12

 02.0513 Curb Cut12

 02.0514 Density12

 02.0515 Drive-in Retail12

 02.0516 Dwelling.....12

 02.0517 Environmental Impact Statement.....13

 02.0518 Family13

 02.0519 Fence, Sight-Obscuring.....13

 02.0520 Floor Area13

 02.0521 Fractional Numbers or Measurements14

 02.0522 Garage, Private.....14

 02.0523 General Plan.....14

 02.0524 Grade.....14

 02.0525 Guest14

 02.0526 Height of Building14

 02.0527 Home Occupation14

 02.0528 Junk Yard14

 02.0529 Kennel14

 02.0530 Landscaping15

 02.0531 Land Use Plan15

 02.0532 Land Use Ordinance15

 02.0533 Large Scale Development15

 02.0534 Livestock Corral.....15

 02.0535 Lodging House.....15

CHARLESTON TOWN

02.0536	Lot.....	15
02.0537	Manufactured Home	15
02.0538	Mobile Home	16
02.0539	Mobile Home Park	16
02.0540	Motel --- Tourist Home --- Motor Hotel.....	16
02.0541	Non-conforming Building.....	16
02.0542	Non-conforming Use	16
02.0543	Nursery or Day Care	16
02.0544	Open Space	16
02.0545	Parking Space.....	16
02.0546	Pasture.....	16
02.0547	Planned Unit Development	16
02.0548	Planting Plan	16
02.0549	Premise.....	17
02.0550	Premise Occupation	17
02.0551	Public Parks and Playground	17
02.0552	Recreational Vehicle -- Camper -- Travel Trailer -- Motor Home -- Vacation Vehicle	17
02.0553	Recreational Vehicle Court --- Vacation Vehicle Court.....	17
02.0554	Rest Home -- Nursing Home -- Convalescent Home	17
02.0555	Salvage Yard.....	17
02.0556	Setback.....	17
02.0557	Special Exception --- Conditional Use	17
02.0558	Street. Major	17
02.0559	Street. Minor	17
02.0560	Subdivision	18
02.0561	Variance	18
02.0562	Yard.....	18
02.0600	SUPPLEMENTARY REQUIREMENTS AND PROCEDURES APPLICABLE WITHIN ALL ZONES.....	18
02.0601	Intent	18
02.0602	Yard Space for One Building Only.....	18
02.0603	Every Dwelling to Be on a Zoning Lot.....	19
02.0604	Sale or Lease of Required Space Prohibited.....	19
02.0605	Yards to be Unobstructed - Exceptions	19
02.0606	Area of Accessory Building.....	19
02.0607	Accessory Building Prohibited as Living Quarters	19
02.0608	Storage of Commercial Vehicles in Residential Zones	19
02.0609	Storage of Junk and Debris.....	19
02.0610	Additional Height Allowed for Public Buildings	19
02.0611	Height of Dwellings and Fences	19
02.0612	Location of Barns.....	20
02.0613	Drainage.....	20
02.0614	Clear View of Intersection Streets	20
02.0615	Effect of Street Plan	20
02.0616	Residential Exception to Front and Side Setback Requirements.....	20
02.0617	Concessions in Public Parks and Playgrounds.....	20

CHARLESTON TOWN

02.0618	Sewage Disposal	20
02.0619	Design and Location of Gasoline Pump Island and Canopies	20
02.0620	Landscaping Required	21
02.0621	General Landscaping Provisions.....	21
	A. Scope of Requirements	21
	B. Maintenance	21
	C. Screening Requirements.....	21
	D. Plot Plan Required	21
	E. Non-Conforming Status.....	21
02.0622	Signs	21
	A. Definitions.....	22
	Abandoned or Obsolete Sign	22
	Animated Sign	22
	Backlit Sign.....	22
	Banner	22
	Billboard	22
	Building-Mounted Sign	22
	Canopy Sign.....	22
	Center Sign.....	22
	Decorative Sign.....	23
	Dedication Plaques.....	23
	Development-Entrance Sign	23
	Directional Sign	23
	Flag	23
	Free Standing Sign.....	23
	Governmental Sign	23
	Grand Opening Pennant, Banner and Display	23
	Identification Sign.....	23
	Illuminated Sign.....	23
	Incidental Sign	23
	Maintenance	23
	Menu Board	23
	Non-Conforming Sign	23
	Off-Premise Sign	24
	On Premise Sign	24
	Pennant.....	24
	Political Sign.....	24
	Projecting Sign.....	24
	Property Sale, Rental, or Lease Sign	24
	Public Utility Sign.....	24
	Sign	24
	Sign Structure.....	24
	Temporary Development	24
	Temporary Holiday Decorations.....	24
	Temporary Sign	24
	Wall-Mounted Sign.....	24
	Window Sign	24
	B. Sign Regulation.....	25

CHARLESTON TOWN

C. Size Adjustments.....	25
D. Removal of Abandoned or Obsolete Signs	25
02.0622E Sign Regulations Table	25
02.0622F Sign Regulations Notes.....	27
02.0623 Pollution Prevention.....	28
02.0624 Recreation Vehicle and Mobile Homes Prohibited --- Exceptions	28
02.0625 Guarantees and Covenants.....	28
A. Declaration of Covenants.....	28
B. Declaration Provisions	28
C. Architectural Committee.....	28
D. Amending Declaration	28
E. Maximum Percentage of Lot Area	28
F. Use Restrictions	28
G. Maintenance	29
H. Town Rights.....	29
02.0626 Lighting.....	29
A. Lighting Plan Submission	29
B. Parking Lighting.....	29
C. Lighting Fixtures on Private Property.....	29
D. Lighting Fixtures on Public Property.....	29
02.0626HR Heber Power and Light Specifications.....	30
E. Exterior Light	31
F. Incident Light.....	31
G. Night Skies Protection	31
H. Outdoor Lighting Fixtures	31
I. Light Trespass Standard	31
J. Shielding Configuration	31
K. Motion Sensing Light Fixtures	31
L. Neon Building Lights	31
M. Architectural/Landscaping Lighting.....	31
N. Emergency Lighting.....	32
O. Mercury Vapor or Metal Halide Light Fixtures.....	32
P. Service Station/Convenience Store Canopy Lighting	32
02.0627 Phasing of Commercial, Industrial or Residential Development Plans.....	32
02.0628 OFF STREET PARKING, ACCESS AND LOADING.....	32
02.0629 Off-Street Parking, Access, and Loading Standards.....	33
A. New Development Access to Public Street.....	33
B. Streets Design.....	33
C. Access Design	33
D. Reciprocal and Shared Driveways	33
E. Spacing of Access Points.....	33
F. Internal Driveways Widths.....	34
G. Loading and Delivery Areas	34
H. Defined Pedestrian Access.....	35
I. Fee to Defer Construction of Improvements	35
J. Pedestrian Walkways	35
K. Pedestrian Walkway Pavement.....	35
L. Vehicle and Pedestrian Movement.....	35

CHARLESTON TOWN

M.	Landscape Accommodations.....	35
N.	Light Reflected Away from Residential Zone	35
O.	Plot Plan Submission for Additional Parking	35
P.	Parking for 5000 sq. Foot Building	35
Q.	Off-Street and Loading Facilities Obligation.....	36
R.	Commercial, Industrial, and Institutional. Developments.....	36
S.	Parking Paving Material	36
T.	Drainage	36
U.	Parking Provided on Same Lot	36
V.	Common Parking Not in Residential Zones	36
W.	Off-Premises Parking with Approval of Planning Commission.....	36
X.	Combined Use Parking	36
Y.	Back Up Space	37
Z.	Parking Areas Borders.....	37
AA.	Parking Structures Considered Buildings	37
BB.	Minimum Design Standards	37
CC.	All Parking Areas Lit.....	37
DD.	Parking Stalls Location	37
EE.	Parking in Residential to Accommodate Emergency Access	37
FF.	Parking in Residential to Accommodate Recreational Vehicles	37
GG.	Parking to Accommodate Landscaping Islands	37
HH.	Parking Ratios	38
II.	Parking for Disabled Persons	40
JJ.	Landscaping Required Surrounding Off-Street Parking Space	40
KK.	Off-Street Loading Space Required	40
	CONDITIONAL USES – GENERAL.....	40
02.0630	Conditional Use Permit	40
02.0631	Conditional Use Permit Required	41
A.	General Standards for Conditional Use Approval	41
B.	General Standards for Imposing Conditions to Approvals	41
C.	Imposition of Conditions to the Approval	42
D.	Denial of a Conditional Use Permit	43
E.	Site Plan Review for Conditional Use Permit	44
F.	Application for Conditional Use Permit	44
G.	Conditional Use Permit Application Review	44
02.0632	Home Occupations and Business Licenses.....	45
02.0632.01	Home Occupations Generally	45
02.0632.02	Home Business Licensure.....	45
02.0632.03	Prohibited Activities As A Home Occupation Business.....	46
02.0632.04	Requirements Specific To Home Occupation Business Licensure.....	47
02.0632.05	Preschools-Additional Requirements	48
02.0632.06	Home Occupation Business License Application Review Procedure	49
02.0632.07	Home Occupation Business License Application Appeal Procedure	49
02.0632.08	Home Occupation Business License Renewal.....	49
02.0632.09	Revocation Of A Home Occupation Business License	49
02.0634	Small Lots	50
02.0635	Utility Buildings and Structures Permitted.....	50
02.0636	Dwelling Sites to have Frontage on a Public Street.....	50

CHARLESTON TOWN

02.0637	Uses Prohibited in Zones Unless Expressly Permitted	50
02.0638	Moved Buildings.....	50
02.0639	Transitional Uses	51
02.0640	Bed and Breakfast Inns	52
02.0641	Zoning (Land Use) Permit	52
02.0642	Flag Lots and Private Streets	52
	A. Purpose.....	52
	B. Section Definitions	52
	C. Requirements.....	52
	D. Restrictions.....	54
	E. Noticing to Neighbors	54
	F. List of Concerns.....	54
	G. Notice of Public Hearing to Owners of Real Property.....	54
02.0643	Building Height.....	54
02.0644	Caretaker Dwelling Requirements and Restrictions	55
02.0645	Landscaping and Other Berms.....	55
02.0700	GENERAL PROVISIONS	56
02.0701	Intent	56
02.0702	Non-conforming Buildings and Uses.....	56
	Damaged Building May Be Restored.....	57
	Discontinuance or Abandonment	57
	Change to a Conforming Use	57
	Change to Another Non-Conforming Use Prohibited.....	57
	Reclassification of Territory.....	57
	Permits Granted Prior to Passage of this Ordinance or Amendment Thereto ..57	
	Width Requirements.....	57
02.0703	Non-conforming Lots of Record.....	57
02.0704	Annexations	58
02.0705	Amendments to Ordinance and Map	58
	Zone Change and Amendment To Procedures	58
02.0706	Notice to Neighbors	58
02.0800	ESTABLISHMENT OF ZONES.....	58
02.0801	Zones Established	58
02.0802	Official Zone Map.....	59
02.0803	Boundaries of Zones	59
02.0900	REGULATIONS WITHIN ZONES	59
02.0904	C-1 COMMERCIAL ZONE.....	59
02.0904.01	Objectives and Characteristics of Zone	59
02.0904.02	Use Requirements	60
	A. Permitted Principal Uses.....	60
	B. Permitted Secondary Uses.....	61
	C. Conditional Uses	61
	D. Prohibited Uses	62
02.0904.03	Area, Width, Location, and Height Requirements.....	63
02.0904.04	Special Provisions.....	63

CHARLESTON TOWN

A. Landscaping	63
B. Parking	64
C. Lighting	64
D. Garbage, Recycling and Other Similar Waste Containers	64
E. Architectural Design.....	64
F. Business Licenses	66
02.0904.05 Site Plan and Platting Requirements.....	66
02.0908.00 G-2 GRAZING ZONE.....	66
02.0908.01 Objectives and Characteristics of Zone	66
02.0908.02 Use Requirements	66
02.0908.03 Area, Width, Location, Height, and Size of Buildings Requirement	67
02.0908.04 Supplementary Requirements and Procedure Applicable Within All Zones	67
02.0909.00 RA-5 RESIDENTIAL – AGRICULTURAL ZONE.....	67
02.0909.01 Objectives and Characteristics of the Zone	67
02.0909.02 Use Requirements	67
02.0909.03 Area Requirements.....	68
02.0909.04 Width Requirements	68
02.0909.05 Location Requirements	68
02.0909.06 Size of Dwellings.....	68
02.0909.07 Special Provisions.....	68
02.0909.08 Supplementary Requirements and Procedure Applicable Within All Zones.....	69
02.0910.00 RA-1 RESIDENTIAL - AGRICULTURAL ZONE.....	69
02.0910.01 Objectives and Characteristics of the Zone	69
02.0910.02 Use Requirements	69
02.0910.03 Area Requirements.....	70
02.0910.04 Width Requirements	70
02.0910.05 Location Requirements	70
02.0910.06 Size of Dwellings.....	70
02.0910.07 Special Provisions.....	70
02.0910.08 Cluster and Farm Subdivisions	71
A. Purpose and Intent	71
B. Use Regulations	71
C. Development Standards.....	71
D. Farm Area and Open Space Provision and Maintenance	73
E. Cluster or Farm Subdivision Application.....	73
02.0910.09 See also Supplementary Requirements and Procedures Applicable Within All Zones.....	73
02.0911.00 INDUSTRIAL (I) ZONE.....	73
02.0911.01 Objectives & Characteristics of the Industrial (I) Zone.....	73
02.0911.02 Existing Legal Nonconforming Industrial Uses	73
02.0911.03 Industrial Zone And Use Criteria.....	73
02.0911.04 Floor Area And Lot Coverage	74
02.0911.05 Lot Width.....	74
02.0911.06 Setback Requirements.....	74
02.0911.07 Parking	74
02.0911.08 Building Height.....	74

CHARLESTON TOWN

02.0911.09	Special Requirements.....	74
02.0911.10	Permitted Uses	75
02.0911.11	Conditional Uses	75
02.0911.12	Supplementary requirements and Procedures Applicable Within All Zones.....	75
02.1000	SEXUALLY ORIENTED BUSINESSES	75
02.1100	ADMINISTRATION AND ENFORCEMENT	76
02.1101	Building Permits Required, Application.....	76
02.1102	Plans Required	76
02.1103	Permits to Comply with Ordinance.....	76
02.1104	License to Comply with Ordinance	76
02.1105	Construction and Use to Comply with Application.....	76
02.1106	Certificate of Zoning Compliance Required.....	76
02.1107	Zoning Administrator Appointed.....	77
02.1108	Powers and Duties of Zoning Administrator	77
02.1109	Land Use Appeal Authority Created, Members, Terms	77
02.1110	Organization, Meetings, Records.....	77
02.1111	Powers and Duties of the Land Use Appeal Authority	78
02.1111.01	Interpret Ordinance and Map	78
02.1111.02	Grant Variances	78
02.1111.03	Grant Certain Special Exceptions or Conditional Uses	78
02.1111.04	Transitional Uses	79
02.1112	May Attach Reasonable Conditions.....	79
02.1113	May Reverse or Affirm Zoning Administrator	79
02.1114	Authority Limited	80
02.1115	Vote.....	80
02.1116	Application to Appear Before the Land Use Appeal Authority	80
02.1117	Procedure	80
02.1118	Hearing.....	80
02.1119	Action of the Land Use Appeal Authority	81
02.1120	Recourse from Decision of Board.....	81
02.1121	Powers and Duties of the Planning Commission.....	81
02.1122	Powers and Duties of the Municipality.....	81
02.1200	SEPARABILITY	81
02.1300	RESPONSIBILITY FOR VIOLATIONS.....	82
02.1400	PENALTY	82
02.1500	EACH DAY OF VIOLATION A SEPARATE VIOLATION.....	82
02.1600	CONFLICTING PROVISIONS REPEALED.....	82
02.1700	EFFECTIVE DATE.....	82

CHARLESTON TOWN

02.0100 TITLE, INTENT, AND PURPOSE

BE IT ORDAINED BY THE Board of Trustees of Charleston Town, Utah that this ordinance shall be known as, and shall be entitled:

THE LAND USE ORDINANCE OF CHARLESTON TOWN, UTAH-

An ordinance establishing zones within Charleston Town, Utah; regulating and restricting within said zones the use, location, heights, and size of buildings and structures, the use of land, the size of lots, yards, and other open spaces; providing methods of administration and enforcement; providing penalties for the violation thereof; repealing all other ordinances and parts of ordinances in conflict herewith.

It is the intent and purpose of the Town Council of Charleston Town, Utah, to promote the health, safety, morals, convenience, order, prosperity, and general welfare of the present and future inhabitants of the Town by guiding development within said Town in accordance with a general plan which plan has been designed:

1. To encourage and facilitate orderly growth and development in the area.
2. To promote safety from fires, floods, traffic hazards, and other dangers.
3. To promote sanitation and the health of the inhabitants.
4. To discourage undue scattering of population and unnecessary expenditures of the monies for excessive streets, water and sewer lines, and other public requirements.
5. To stabilize and improve property values.
6. To protect the residents from objectionable noise, odor, dust, fumes, and other deleterious substances or conditions.
7. To promote a more attractive and wholesome environment.

02.0200 APPLICATION

The regulations and restrictions as set forth in this Ordinance shall be interpreted and applied as to further the purposes of this Ordinance.

02.0300 DECLARATION

In establishing the zones, the boundaries thereof, and regulations and restrictions applying within each of the zones, due and careful consideration was given, among other things, to the suitability of the land for particular uses, and to the character of the zone, with a view to conserving the value of buildings and encouraging the most appropriate use of land throughout the Town. Rezoning decisions shall be a discretionary legislative function.

02.0400 INTERPRETATION

In interpreting and applying this Ordinance, the provisions thereof shall be held to be the minimum requirements adopted for the promotion of public health, safety, comfort, convenience, and general welfare. **Except as specifically herein provided**, it is not intended by the adoption of this Ordinance to repeal, abrogate, annul, or in any way to impair or interfere with any existing provisions of law or ordinance, or any rules, regulations, or permits previously adopted or issued or which shall be adopted or issued, which do not conflict with

CHARLESTON TOWN

the provisions here of, pursuant to law relating to the creation, construction, establishment, moving, alteration or enlargement of any building or improvement, nor is it intended by this Ordinance to interfere with or abrogate or annul any easement, covenant, or other agreement between parties, provided, however, that in cases in which this Ordinance imposes a greater restriction than is imposed or required by other existing provisions of law or ordinance, then in such case the provisions of this Ordinance shall control.

02.0500 DEFINITIONS

02.0501 Intent

It is the intent of the Town Council to define certain words and phrases as a means of facilitating understanding of terms which may not be universally understood in the sense that the Board of Trustees intends that they should be understood. Words used in the present tense include the future, the singular includes the plural, and the plural the singular. The term "Town Council" is synonymous with the term "Board of Trustees."

02.0502 Agriculture

Agriculture shall mean the cultivation of the soil and the raising of livestock.

02.0503 Boarding House -- Lodging House

A building containing not more than one kitchen, where for compensation, meals are provided pursuant to previous arrangements on a daily, weekly, or monthly basis as distinguished from a motel, care, or rooming house.

02.0504 Building

Any structure built for the support, shelter, or enclosure of persons, animals, chattels, or property of any kind.

Building, Accessory

A subordinate building, the use of which is incidental to that of the main building.

Building, Main

The principal building upon a lot.

Building, Line

A line designating the minimum distance which buildings must be set back from a street or lot line.

02.0505 Caretaker Dwelling

A dwelling, on the same site as a primary residence, commercial building, commercial or industrial operation or plant and occupied by a caretaker or security person for that residence, operation or plant.

02.0506 Carport

A structure not completely enclosed by walls for the shelter of automobiles.

02.0507 Clinic

A building used for the diagnosis and treatment of ill, infirm, and injured persons, but which building does not provide board, rooms, or regular hospital care and services. A veterinary clinic is a building used for the diagnosis and treatment of ill, infirm, or injured animals.

CHARLESTON TOWN

02.0508 Club

A building used, occupied, and operated by an organized association of persons for social, fraternal, religious, or patriotic purposes, whose activities are confined to the members and their guests, but shall not include an organization, group or association, the principal activity of which is to render a service usually and ordinarily carried on as a business.

02.0509 Common Area

An area designed to serve two or more dwelling units or separate uses with convenient access to the area.

02.0510 Conditional Use

Generally, a use which requires approval of the Planning Commission, Land Use Appeal Authority, or Town Council before the Zoning Administrator may issue a permit, therefore. Uses which require individual consideration of surrounding conditions and circumstances to carry out the intent and purpose of the General Plan. A use for which a conditional use permit is required by this Ordinance.

02.0511 Convenience Establishments

Establishments which are designed and intended to serve the daily or frequent trade or service needs of the surrounding population. Such establishments include grocery stores, variety stores, drug stores, coin-operated laundry and dry-cleaning establishments, beauty shops, barber shops, or combinations thereof, but do not include repair garages, automobile sales yards, or clothing stores.

02.0512 Convalescent Home

See "Rest Home"

02.0513 Curb Cut

See "Street Standards Ordinance"

02.0514 Density

Density of population measured by the number of dwelling units per acre of land.

02.0515 Drive-in Retail

Any form of merchandising, serving, or dispensing of goods in which the customer is serviced while in his automobile.

02.0516 Dwelling

Dwelling Unit

One or more rooms in a building designed for living purposes, having one kitchen or set of cooking facilities, and an independent water closet and bathing facilities.

Dwelling, One Family

A building containing one (1) dwelling unit, which is designed for or occupied by one (1) family.

Dwelling, Two-Family

A building containing two (2) separate dwelling units each of which is designed for or occupied by one (1) family.

CHARLESTON TOWN

Dwelling, Multiple-Family

A building containing three (3) or more separate dwelling units each of which is designed for or occupied by one (1) family.

Dwelling, Caretaker's

A dwelling on the same site as a primary residence, commercial building, commercial or industrial operation or plant and occupied by a caretaker or security person for that residence, operation or plant.

Dwelling, Bachelor's

A dwelling unit which is occupied by two (2) or more non-related adults.

02.0517 Environmental Impact Statement

A statement prepared by an engineer, geologist, or other person qualified by training or experience, as determined by the Planning Commission, which indicates or describes the impact that the development will likely have on the natural features of the immediate area, and which describes the measures that will be taken to lessen the occurrence of adverse conditions with respect to at least the following:

1. Control of both on-site and off-site erosion.
2. Re-seeding of cuts and fills.
3. Provisions for potable water.
4. Disposition of any geologic hazards or soil conditions which may cause injury to persons or injury or damage to improvements which may be constructed in the development, such as buildings, water and sewer lines, and streets.
5. Provision for the proper disposal of solid and liquid wastes that will likely come from the occupants of the development when it is fully developed.
6. Prevention of fire and control of dust.
7. Prevention of the accumulation of weeds and debris.
8. Prevention of the destruction of vegetation or else the establishment of new vegetation.
9. Disposal of surface water and disposition of flood hazards.
10. Other Aspects. The Planning Commission may require studies of other aspects of the property when needed.

02.0518 Family

An individual or two or more persons related by blood, marriage, or adoption living together in a single dwelling unit and maintaining a common household. A family may include two, but not more than two, non-related persons living as guests with the residing family. The term family shall not be construed to mean a group of unrelated individuals, a fraternity club, or institutional group.

02.0519 Fence, Sight-Obscuring

A fence having a height of at least six (6) feet above grade which permits vision through not more than ten percent (10%) of each square foot more than eight (8) inches above ground.

02.0520 Floor Area

The floor area of a building is the sum of the areas of the several floors of the building, including basements, mezzanines, and penthouses, or headroom heights, measured from the exterior walls or from the centerline of walls separating buildings. The floor area does not

CHARLESTON TOWN

include unoccupied features such as pipe trenches, exterior terraces or steps, chimneys, roof overhangs, etc.

02.0521 Fractional Numbers or Measurements

In determining the requirements of this Ordinance, whenever a fraction of a number or a unit is $1/2$ or more, and whenever a fraction of a number or a unit resulting from a computation is $1/2$ or more, said fraction shall be considered as a whole number or a unit. Where the fraction is less than $1/2$, said fraction shall not be included in determining requirements.

02.0522 Garage, Private

A building or part thereof designed for the parking or temporary storage of automobiles of the occupants of the premises.

02.0523 General Plan

A coordinated plan, which has been prepared and adopted for the purpose of guiding development.

02.0524 Grade

For buildings fronting one street only:

The elevation of the sidewalk or centerline of street, whichever is higher, at right angles to the midpoint of the fronting wall

For buildings fronting on more than one street:

The average of the elevations of the sidewalk or centerline of street, at right angles to the mid-point of the fronting walls.

For buildings having no wall fronting the street:

The average level of the sidewalk or center line of surrounding streets, whichever is higher.

02.0525 Guest

A person staying or receiving services for compensation at a hotel, motel, bed and breakfast, boarding house, rooming house, or rest home, or similar use.

02.0526 Height of Building

The vertical distance from the grade to the highest point of the building exclusive of chimneys and antennas.

02.0527 Home Occupation

Any occupation conducted within a dwelling and carried on by persons residing in the dwelling.

02.0528 Junk Yard

A place where scrap, waste, discarded or salvaged materials are bought, sold, exchanged, baled, packed, disassembled, handled, or stored, including auto wrecking yards, house wrecking yards, used lumber yards, and places or yards for storage of salvaged house-wrecking and structural steel materials and equipment, but not including such places where such uses are conducted entirely within a completely enclosed building or where salvaged materials are kept incidental to manufacturing operations conducted on the premises.

CHARLESTON TOWN

02.0529 Kennel

Land or building used in the keeping of four or more dogs over four months old.

02.0530 Landscaping

Landscaping shall mean some combination of planted trees, shrubs, vines, ground cover, flowers, or lawns. In addition, the combination or design may include rocks and such structural features as fountains, pools, art works, screens, walls, fences, or benches, but such objects alone shall not meet the requirements of this Ordinance.

02.0531 Land Use Plan

A plan adopted and maintained by the Town Council which shows how the land should be used. This shall be an element of the General Plan.

02.0532 Land Use Ordinance

The Zoning Ordinance shall serve as the Land Use Ordinance.

02.0533 Large Scale Development

A development that contains two (2) or more main buildings on a zoning lot in which development is planned and developed as a single entity.

02.0534 Livestock Corral

A place or pen where livestock are kept on a seasonal basis as part of an agricultural enterprise or operation as distinguished from a livestock feed yard.

02.0535 Lodging House

See "Boarding House" or "Bed and Breakfast"

02.0536 Lot

A single parcel or tract of land.

Lot, corner

A lot situated at a junction of two public streets or situated on a curved street or way, the radius of which is thirty-five (35) feet or less and where the angle formed by the intersection or the tangent is one hundred five (105) degrees or less.

Lot, interior

A lot other than a corner lot

Lot of record

A lot designated on a subdivision plat or deed, duly recorded pursuant to statute in the county recorder's office. A lot of record may or may not coincide with a zoning lot.

Lot, zoning

A parcel of land, composed of one or more recorded lots, occupied or to be occupied by a principal building or buildings or principal use or uses along with permitted accessory buildings or uses, meeting all the requirements for area, buildable area, frontage, width, yards, setbacks, and any other requirements set forth in the Ordinance.

02.0537 Manufactured Home

CHARLESTON TOWN

A dwelling unit which meets the building code for permanent structures designed to be transported after fabrication and which is ready for occupancy as an independent unit except for connection to utilities and location on a foundation. Made after 6/15/76

02.0538 Mobile Home

A vehicular or portable structure which is constructed for movement on the public highways, which is designed for use as a residence, but which has not been demonstrated to conform to the requirements of the building code for other residences. Made on or before 6/15/76

02.0539 Mobile Home Park

An area or tract of land used to accommodate two or more mobile homes.

02.0540 Motel --- Tourist Home --- Motor Hotel

This shall mean one or more buildings containing individual sleeping rooms or living units designed for use by automobile tourists or transients with garage attached or parking space conveniently located to each unit.

02.0541 Non-conforming Building

A building, structure, or portion thereof, which does not conform to the regulations of this Ordinance applicable to the zone or district in which such building is situated but which was in existence on the effective date of this Ordinance.

02.0542 Non-Conforming Use

A use of premises which does not conform to the regulations of this Ordinance, but which was in existence on the effective date of this Ordinance.

02.0543 Nursery or Day Care

A home or building in which children are tended or kept for compensation. Does not include overnight accommodations for such children, as does a foster home or an orphanage.

02.0544 Open Space

Open space is that portion of the yards on a zoning lot which is not used by automotive vehicles, but reserved for outdoor living space, recreational space, and landscaping.

02.0545 Parking Space

Space within a building or parking area, exclusive of driveways, ramps, columns, office and working area, for the parking of a motor vehicle, not less than twenty (20) feet in length and not less than eight and five-tenths (8.5) feet in width.

02.0546 Pasture

An enclosure for animals in which no feed is provided except for that which the animals obtain by grazing.

02.0547 Planned Unit Development

A tract of land which is planned and developed as a single entity wherein the requirements applying to all buildings and improvements are modified to conform to the approved plan.

02.0548 Planting Plan

CHARLESTON TOWN

A plan showing the location and dimensions of plants, irrigation equipment, curbs and other protective features around the edge of the planting beds and the location and species of plants to be planted.

02.0549 Premise

A zoning lot together with buildings and structures located thereon.

02.0550 Premise Occupation

An occupation conducted on the premises outside of a dwelling owned by persons residing on the premises. The premise occupation business shall be operated by a property owner holding at least 51% interest in the parcel for which the premise occupation is approved.

02.0551 Public Parks and Playgrounds

Shall mean a tract of land which is owned by the public and which has been partially or totally developed or designated for recreational purposes.

02.0552 Recreational Vehicle -- Camper -- Travel Trailer -- Motor Home -- Vacation Vehicle

A vehicular unit, other than a mobile home, primarily designed as a temporary dwelling for travel, recreational and vacation use, which is either self-propelled or is mounted on or pulled by another vehicle; including but not limited to: a travel trailer or camping trailer having a width of eight (8) feet or less and a length of thirty-two (32) feet or less, a truck camper, and motor home comprised of a self-propelled vehicle primarily designed as a temporary dwelling for travel, recreational use, and vacation use.

02.0553 Recreational Vehicle Court --- Vacation Vehicle Court

An area or tract of land used to accommodate two or more recreational vehicles.

02.0554 Rest Home -- Nursing Home -- Convalescent Home

A building for the care and keeping of elderly or infirm people afflicted with infirmities or chronic illness.

02.0555 Salvage Yard

See Junk Yard

02.0556 Setback

The shortest distance between the property line and the foundation, wall, or main frame of the building.

02.0557 Special Exception --- Conditional Use

A use which is not specifically permitted in a zone, such as an industrial use in a residential zone, but which is permitted as a special exception to the Ordinance subject to compliance with conditions prescribed by the Town Council, Planning Commission, or Land Use Appeal Authority.

02.0558 Street. Major

One of the principal thorough-fares, as shown or designated on the Major Street Plan.

CHARLESTON TOWN

02.0559 Street. Minor

Any dedicated street serving as the principal means of access to property, which street is not shown on the Major Street Plan, as a principal thoroughfare.

02.0560 Subdivision

The term "subdivision" means the division of a tract or lot or parcel of land into two or more lots, plots, sites, or other division of land for the purpose, whether immediate or future, of sale or of building development; provided that this definition shall not include a bona fide division or partition of agricultural land for agricultural purposes or of commercial, manufacturing, or industrial purposes.

02.0561 Variance

A waiver of specific regulations of this Ordinance granted by the Land Use Appeal Authority's in accordance with the provisions set forth in this Ordinance for the purpose of assuring that no property because of special circumstances applicable to it shall be deprived of privileges commonly enjoyed by other properties in the same zone.

02.0562 Yard

An open space on the same lot with a building unoccupied or unobstructed from the ground upward, except as otherwise provided in this Ordinance.

Yard, Front

The minimum horizontal distance between the street line and the front line of the building or any projection thereof, excluding non-enclosed steps. On a corner lot, the front yard may be applied to either street.

Yard, Rear

An open, unoccupied space on the same lot as a building, measured from the rear line of the building (exclusive of steps) and the rear lot line, and extending for the entire width of the lot. In case of a corner lot, where the building facade faces on the side street, the rear yard may be established from the side of the house to the side property line.

Yard, Required

The open space around buildings which is required by the term of this Ordinance.

Yard, Side

A yard between the building and the sideline of the lot and extending from the front yard to the rear yard.

02.0600 SUPPLEMENTARY REQUIREMENTS AND PROCEDURES APPLICABLE WITHIN ALL ZONES

02.0601 Intent

The intent of this section is to accumulate under one heading, regulations which apply to two or more zones, rather than to repeat them several times.

02.0602 Yard Space for One Building Only

No required yard or other open space around an existing building, nor yard or other open space, which is hereafter required around any building, which is needed to comply with the provisions of this Ordinance shall be considered as providing a yard or open space for any

CHARLESTON TOWN

other building; nor shall any yard or other required open space on an adjoining lot be considered as providing the yard or open space on the lot whereon a building is to be erected or established.

02.0603 Every Dwelling to Be on a Zoning Lot

Only one building which contains a dwelling shall be located and maintained on a zoning lot as defined in this Ordinance, except for dwellings located within a planned unit development, mobile home park, or other large-scale development.

02.0604 Sale or Lease of Required Space Prohibited

No space needed to meet the width, yard, area, coverage, parking, or other requirements of this Ordinance for a lot or building may be sold or leased apart from such lot or building unless other space so complying is provided.

02.0605 Yards to be Unobstructed --- Exceptions

Every part of a required yard shall be open to the sky and unobstructed except for permitted accessory buildings and except for ordinary and customary projection of sills, belt courses, cornices, and other ornamental features and unenclosed steps and un-walled stoops, porches, and carports, which may project up to three feet into a required yard. No projection into a required court which is provided in connection with a court apartment shall be constructed except for customary sills, belt courses, and cornices which may extend into the court not more than sixteen inches.

02.0606 Area of Accessory Building

Accessory buildings in any residential zone shall cover not more than twenty-five percent (25%) of the rear yard.

02.0607 Accessory Building Prohibited as Living Quarters

Living quarters in any building other than the main residential building is prohibited, except as specifically otherwise allowed within this Ordinance.

02.0608 Storage of Commercial Vehicles in Residential Zones

The storage and/or continuous parking of commercial and construction equipment not to exceed one (1) tractor-trailer combination shall be permitted in residential zones, provided that equipment must be stored on or in front of the driver's premises and at least 6 feet off the pavement. The restrictions may be different for Premise Occupations.

02.0609 Storage of Junk and Debris:

See requirements within the Charleston Town Nuisance Abatement Ordinance

02.0610 Additional Height Allowed for Public Buildings

Public buildings and churches may be erected to a height of 35 feet exclusive of spires and steeples, which may be built to a maximum of 50 feet high, provided the building is set back from required building setback lines a distance of at least one (1) foot for each additional foot of steeple or spire height above the maximum height otherwise permitted in the zone in which the building is located.

CHARLESTON TOWN

02.0611 Height of Dwellings and FencesNo dwelling shall be erected which has a ceiling height of less than 7'6" or one story above natural grade, whichever is greater. No fence or wall shall be constructed higher than four feet above the ground in any required front or side yard that fronts on a street, except that in agricultural zones such fences may be constructed to a height of six feet. In no case shall any fence or wall exceed 6 feet in height.

02.0612 Location of Barns

No barn, corral, or coop shall be constructed closer than 100 feet from any existing dwelling on a neighbor's property or public street, nor 30 feet from owner's dwelling, nor shall any corral, pen or coop be constructed or maintained closer than 20 feet to any open waterway that drains into a natural stream. Surface drainage from corrals, pens or coops shall not be permitted to drain into a waterway that drains into a natural stream.

02.0613 Drainage

Surface water from rooftops, lots or irrigation ditches shall not be allowed to drain onto adjacent lots or streets except upon written agreement between the parties involved.

02.0614 Clear View of Intersection Streets

In all zones which require a front yard, no obstruction which will obscure the view of automobile drivers shall be placed on any corner lots within a triangular area formed by the street property lines and a line connecting them at points of forty-five (45) feet from the intersection of the street lines.

02.0615 Effect of Street Plan

Wherever a front or side yard is required for a building which abuts on a proposed street which has not been constructed but which has been designated by the Planning Commission as a future street, the depth of such front or side yard shall be measured from the planned street lines.

02.0616 Residential Exception to Front and Side Setback Requirements

The setback from the street for any dwelling located between two existing dwellings in any residential zone may be the same as the average for said two existing dwellings, provided the existing dwellings are on the same side of the street and are located within one hundred fifty feet of each other.

02.0617 Concessions in Public Parks and Playgrounds

Concessions, including but not limited to amusement devices, recreational buildings, and refreshment stands, shall be permitted on a public park or playground when approved by the Town Board.

02.0618 Sewage Disposal

Where domestic sewage disposal facilities are used, which are not connected to a public sewer, approval of such facilities shall be obtained from the Health Department before a building permit shall be issued.

02.0619 Design and Location of Gasoline Pump Islands and Canopies

Gasoline pump islands and canopies shall be designed to match the primary structure and shall be set back not less than twenty (20) feet from any street line to which the pump island/canopy

CHARLESTON TOWN

is parallel and fifteen (15) feet from any street line to which the pump island/canopy is perpendicular and not less than one-hundred (100) feet, for either parallel, perpendicular or angular configurations, from any residential zone boundary line. Fuel pump islands and canopies shall have a setback of at least fifty (50) feet from any highway right-of-way. In no case shall pumps, islands or canopies be set closer than thirty (30) feet from any property line other than the street line. Lots from which gasoline is dispensed to customers at retail shall be not less than one hundred-fifty (150) feet by one hundred-fifty (150) feet in size.

02.0620 Landscaping Required

At least seventy percent (70%) of the area contained within a required front or side yard adjacent to a street in any residential-agricultural-commercial zone shall be landscaped. Also, other landscaping shall be required in other zones as specified.

02.0621 General Landscaping Provisions

The purpose of the landscaping requirements in this Ordinance shall be to enhance, conserve, and stabilize property values by encouraging pleasant and attractive surroundings and thus create the necessary atmosphere for the orderly development of a pleasant community. Landscaping also contributes to the relief of heat, noise, and glare through the proper placement of green plants and trees.

- A. **Scope of Requirements.** Where landscaping is required, such landscaping shall comply with the requirements set forth in the Ordinance for the specific use and location. Where an individual zone contains stricter landscaping requirements than this section, those requirements shall govern.
- B. **Maintenance:** Required landscaped areas shall be maintained in a neat, clean, orderly, and healthful condition. This is meant to include proper pruning, mowing lawns, weeding, removal of litter, fertilizing, replacement of dead plants and the regular watering of all planting.
- C. **Screening Requirements.** Where landscape screening is required, said screening shall consist of evergreen shrubs, closely spaced and maintained at substantially the specified height of said required screening. When not otherwise specified, natural screening shall be maintained at a height of from four (4) to six (6) feet.
- D. **Plot Plan Required.** Where landscaping is required in this Ordinance, a plot plan showing the proposed landscape development, watering system, and use of the property shall be submitted to the Planning Commission. The same plot plan used to show parking layout or other requirements for the site plan approval may be used to show landscaping providing all proposed landscaping is detailed adequately on said plot plan. The Planning Commission may disapprove such plans if determined that the plans are not consistent with the requirements and purposes of this ordinance.
- E. **Non-Conforming Status of Landscaping.** Any use of property, which, on the effective date of this Ordinance, is non-conforming only as to the regulations relating to landscaping may be continued in the same manner as if the landscaping were conforming.

02.0622 Signs

Identification is vital to the success of any business. These provisions regarding the regulation of signage have been created to promote signage that will be consistent with the nature of the Charleston Town setting. The intention of this provision is to create signs that are colorful,

CHARLESTON TOWN

interesting, and tastefully designed and that will inform, stimulate interest, and identify the business to which it is related.

The Zoning Administrator shall act in a timely manner on the consideration of sign approvals. In review of signage, the Zoning Administrator shall review the proposed sign for compatibility with the property it represents and the immediate vicinity of the commercial area in which it is located.

The following regulations shall apply to all signs in Charleston installed after the approval date of this ordinance. Handcrafted carved or ornamental iron signs are encouraged. In order to encourage this type of sign, bonuses are allowed in both height and area allowances.

Regardless of cost, no sign, unless specifically exempted in Table 02.0622E, shall be erected or placed within the Town without first making an application for and obtaining a sign permit.

A. Definitions:

1. **Abandoned or Obsolete Sign**: Any sign which does not correctly direct or exhort any person, advertise a bona fide business, lessor, owner, product, activity conducted, or product available either on or off the premises where such sign is displayed for a period of ninety (90) days, shall be considered an obsolete sign.
2. **Animated Sign**: Is the movement, or the optical illusion of movement of any part of the sign structure, design or pictorial segment including the movement of any illumination or the flashing, flickering, or varying of light intensity. The automatic changing of all or any part of the facing of a sign or any sign or part of a sign set in motion by movement of the atmosphere shall be considered to be animation under this code.
3. **Backlit Sign**: A sign with a cabinet that has a light source within and a plastic or similar face.
4. **Banner**: Any sign of lightweight fabric or similar material intended to be hung either with or without frames, possessing characters, letters, illustrations, or ornamentations of any kind. National flags, flags of political subdivisions or other public entity shall not be considered banners for the purpose of this code. Refer to definition of flag.
5. **Billboard**: A sign, regardless of size or type, that has a changeable face or faces and said face or faces are leased for advertising business, services, entertainment, and so forth which is conducted or sold elsewhere than on the premises on which the sign is located.
6. **Building-Mounted Sign**: Signs directly mounted to a building. Building-mounted signs shall include canopy, fascia, parapet, mansard, projecting, and roof/wall mounted signs.
7. **Canopy Sign**: A type of building-mounted sign mounted under and supported by a permanent canopy, arcade, or portal, and the faces of which are perpendicular to the nearest facade.
8. **Center Sign**: (Business, Commercial, or Industrial) A group of three (3) or more businesses associated by common agreement or under common ownership which comprises a contiguous land parcel unit with common

CHARLESTON TOWN

- parking facilities.
9. **Decorative Sign**: A sign and sign frame that are made of the following: Wood (carved, routed, and painted); Rock or Stone; Stucco, Metal (made with a combination of iron, brass, steel, copper, and some painted metals; or a combination of the above. Architectural signs that make use of statuary, fountains, and similar architectural elements shall be considered decorative signs and are also eligible for bonus increases under the decorative sign category.
 10. **Dedication Plaques**: Non-illuminated names of buildings, dates of erection, monument citations, commemorative tables and the like when carved in stone, concrete, metal, or any other permanent type of construction and made an integral part of a permitted structure or made flush to the ground.
 11. **Development-Entrance Sign**: A permanent sign erected at the entrance(s) of a residential or commercial development.
 12. **Directional Sign**: Any sign which is designed and erected solely for the purpose of traffic or pedestrian direction and placed on the property to which or on which the public is directed, and which contains no advertising copy.
 13. **Flag**: Any fabric, banner, or bunting containing distinctive colors, patterns, or symbols, used as a symbol of a government, political subdivision, or other public entity.
 14. **Free Standing Sign**: A sign which is erected on its own self-supporting permanent structure, detached from any supporting elements of a building. Signs on walls or fences which are not an integral part of a building are free-standing signs.
 15. **Governmental Sign**: A sign required by law or sign of a duly constituted governmental body, such as traffic sign, warning sign, or no trespassing sign.
 16. **Grand Opening Pennant, Banner and Display**: Those pennants, banners, or displays used to announce the opening of a new business or special sale.
 17. **Identification Sign**: A sign which directs attention to a business, commodity, service, entertainment or product related to uses on the site where the sign is located, and which is not otherwise defined in this code.
 18. **Illuminated Sign**: A sign whose surface is lighted internally (backlit) or externally (front lit).
 19. **Incidental Sign**: A sign generally informational, that has a purpose secondary to the use of the lot on which it is located, such as "no parking," "entrance," "loading only," "telephone," and other similar directives, No sign with a commercial message legible from a position off the lot on which the sign is located shall be considered incidental.
 20. **Maintenance**: Maintenance is the repairing or repainting of a sign structure; changing of reader panels or directory signs; or renewing copy of which has been made unusable by ordinary wear or tear of weather or accident, which does not exceed fifty percent (50%) of the total replacement value of the sign or sign structure as determined by the Zoning Administrator. "Maintenance" shall not include copy changes due to ownership changes or name changes.
 21. **Menu Board**: A sign for drive-in and drive-thru businesses which lists those items and services available at the premises.
 22. **Non-Conforming Sign**: Signs which lawfully existed within the Town of

CHARLESTON TOWN

Charleston prior to the effective date of this code, but which do not comply with the requirements of this code, and which uninterruptedly continue to advertise the same business name and exist past the effective date of this code in a state of non-compliance, shall be deemed non-conforming signs.

23. **Off-Premises Sign**: A sign which directs attention to a business, commodity, service, entertainment or product not related to use on the premises where the sign is located.
24. **On Premise Sign**: A sign which directs attention to a business, commodity, service, entertainment or product conducted, sold or offered on the premises.
25. **Pennant**: Any lightweight plastic, fabric, or other material, whether or not containing a message of any kind, suspended from a rope, wire, or string, usually in series, designed to move in the wind.
26. **Political Sign**: A temporary sign which supports the candidacy of any candidate or public office or urges action of any other matter on the ballot of primary, general or special elections.
27. **Projecting Sign**: Is a type of building-mounted sign, other than a wall sign or canopy sign, which projects more than twelve (12) inches from and is supported by a wall of a building.
28. **Property Sale, Rental, or Lease Sign**: Temporary sale, rental or lease sign placed on the property to which the sign refers.
29. **Public Utility Sign**: Signs placed by a public utility for the safety, welfare, or convenience of the public, such as signs identifying high voltage, public telephone, or underground cables.
30. **Sign**: Any identification, description, illustration, or device which is affixed directly or indirectly upon a building, structure or land which directs attention to a product, place, activity, person, institution, or business, and which is visible from any public street, alley or public place, BUT NOT TO INCLUDE MENU BOARDS OR BANNERS AS DEFINED IN THIS SECTION. National flags and flags of political subdivisions shall not be construed as signs.
31. **Sign Structure**: The support and framework of the sign.
32. **Temporary Development Sign**: A non-illuminated temporary sign allowed to be erected upon a parcel to designate future occupancy by a business, development or other concern designated thereon.
33. **Temporary Holiday Decorations**: Those temporary decorations used to commemorate a recognized holiday.
34. **Temporary Sign**: Any sign that is used temporarily, NOT TO EXCEED 90 DAYS, and is not permanently mounted, excluding portable signs.
35. **Wall-Mounted Sign**: A sign mounted flat against, projecting less than twelve (12) inches, or painted on the wall of a building or structure with the exposed face of the sign in a plane parallel to the face of said wall.
36. **Window Sign**: Any sign, picture, symbol, or combination thereof, designed to communicate information about an activity, business, commodity, even, sale, or service, that is placed inside a window or upon the windowpanes or glass and is visible from the exterior of the window.

CHARLESTON TOWN

- B. Sign Regulation.** Signs shall be regulated according to Table 02.0622E including the Notes 02.622F.
- C. Size Adjustments.** The Town Board may allow adjustments to maximum sign sizes for all types of signs taking into consideration the surrounding land use, the speed limit of adjacent streets, the size of the property the sign is located on and linear feet of the property along the street that development fronts, surrounding existing businesses and residences, and other factors peculiar to the proposed sign location.
- D. Removal of Abandoned or Obsolete Signs.** Within thirty (30) days after written notice from the Zoning Administrator, obsolete sign copy and abandoned sign structures shall be removed by the owner of the property, his agent, or persons having the beneficial use of the building or structure upon which such sign or sign structure is erected. Failure to comply with such notice within the time specified in such notice shall be considered as a violation of the terms of this code.

Sign Regulations Table 02.0622 E

Use	Sign- No Permit Required	Number Allowed	Maximum Area in Sq Ft	Maximum Height in Lineal Ft
Single-Family Residential Zone (RA-1)	Nameplates	3	2	
	Address Numbers	3	4	
	Sale/Rent/Lease	1	6 - frontage	
	Dedication Plaques	1	4	
	Temp Political Signs			
Commerical Zone (C-1)	Address Numbers	3	2	
	Temp Political Signs			
	Sale/Rent/Lease	1	4	
	Dedication Plaques	1	12	
	Incidental	1	4	
	Window	As	No Limit	
	Grand Opening (2 weeks max)	Approved No Limit	64 Total	
	Temporary Sale Promotion (72 hrs. max)	4	24 Total	
	Pennant Strings (2 weeks max)	4		
		200 lineal feet		

CHARLESTON TOWN

Use	Signs- Permit Required	Number Allowed	Maximum Area in Sq Ft	Maximum Height in Lineal Ft
Single-Family Residential Zone (RA-1)	Temp Development Sign	2	32 total	6
	Dev. Entrance Sign	1/entrance	32	6
	Home Occupation	1	2	
Commercial Zone (C-1)	Temp Develop Sign	2	32 Total	8
	Monument of Ground	1	24 Total & 32 Total for Decorative	8 10 for Decorative See Note 20
	Wall, projecting, or canopy	3	24 Total & 32 Total for Decorative	See Note 4 5 6
	Portable	1		6
	Temp Off-Premise Signs (see footnote 13)	1	See Note	6 12 15 for Decorative
	Menu Board	1	20	
	Gas Price Board	1	16	
	Combined Business or Shopping Center	1 per frontage	8	See Note 20
				16 12 8 per business up to max 48

Sign Regulation Notes 02.0622 F

1. There shall be no illuminated signs in the residential zones.
2. Signs not specifically listed in Table 02.0622 E are not allowed.
3. There shall be no exposed neon, flashing, or animated signs allowed in any zone.
4. No wall, projecting, or canopy sign shall project above the parapet or roofline of the building to which it is attached. Minimum heights shall be 8 feet over waling surfaces and 14 feet over vehicle surfaces.
5. All signs must be decorative signs as described in the definition section of the sign ordinance, if illuminated, signs must be illuminated from the front side. Backlit (or interior lit) signs are not allowed in any zone (backlit signs shall mean a sign with a cabinet that has a light source within a plastic or similar face).
6. Business or Shopping Centers shall be allowed only one ground or monument sign. Sign may contain area for the center name and individual plaques for the businesses within the center as allowed in the table above.
7. Back-to-back signs shall count as one sign and square footage shall be calculated for one side only.
8. No sign shall be placed in a manner as to interfere in any way with or confuse traffic or preset a traffic hazard.
9. Off-premises signs other than ladder signs described in section 13 below are not allowed.
10. Government signs, public utility signs, and temporary political signs are allowed in any district with mot permit required.
11. Decorative tops may exceed the maximum height of approved decorative signs by 18 inches.
12. No billboards shall be allowed in any zone.
13. Ladder style business and real estate development directional signs may be allowed in any zone when approved by the Town Council.
14. No inflatable signs shall be allowed except for temporary sales promotions not to exceed 72 hours.
15. Height of sign is measured from curb to the highest point of the sign structure; if not curb exists, then the height shall be measured from the crown of the road.
16. The sign area shall be measured as per Section 02.0622 E of this Code.
17. Vehicle signs are only allowed as noted in 02.0622.
18. Temporary Holiday Decorations shall be allowed in all zones.
19. In order to receive the bonus, the sign must be as described for a Decorative Sign in the Definitions Section for Decorative Signs printed above.
20. No sign shall be erected that will violate section 02.0622 of the Land Use Ordinance.

CHARLESTON TOWN

2.0623 Pollution Prevention

Any use shall be prohibited which emits or discharges gases, noise, or other pollutants into the atmosphere in amounts which exceed the standards as prescribed by the Utah State Air Quality Board, the Board of Health, or such appropriate body as may be appointed by the Board of County Commissioners. Any use shall also be prohibited which emits or discharges liquids or solid material onto the soil or water in amounts which result in pollutants entering any water or drainage system in amounts exceeding the standards prescribed by the Utah State Water Pollution Control Board or the State Board of Health.

02.0624 Recreation Vehicle and Mobile Homes Prohibited --- Exceptions

It shall be unlawful to place any recreation vehicle on any lot or parcel of land in the area covered by the zoning map and to use the same for human habitation, except for visitors in a self-contained vehicle at a residence for a maximum of 2 weeks or when located in a vacation vehicle court.

It shall be unlawful to place a mobile home on any lot or parcel of land in an area covered by the zoning map and to use the same for human habitation except: when temporarily located on a lot on which a building is being constructed provided the mobile home is connected to approved water and sewer facilities and is not located thereon for more than one year from the date of the issuance of the building permit for the primary building. A payment of \$2,500 will be required before the trailer is moved onto the lot, to be adequate to remove the trailer if left on the lot beyond 1 year. If the trailer is left on the lot for more than 1 year, the \$2,500 is forfeited to the Town.

02.0625 Guarantees and Covenants

Assurances and standards shall be included within the Declaration of Covenants, Conditions, and Restrictions recorded in conjunction with any commercial or industrial development or for a residential development as follows:

- A. As a part of the preliminary plan submission packet, a Declaration of Covenants, Conditions and Restrictions for said development shall be submitted to and be approved by the Planning Commission and Town Attorney and shall be recorded with the Wasatch County Recorder's Office with the Final Plat.
- B. The Declaration shall contain provisions requiring owners of individual parcels of land or condominium units within the development to install landscaping to a standard at least equivalent to that established within the typical landscaping plan approved as an element of the preliminary plan.
- C. The Declaration may provide for the creation and perpetual provision of an architectural committee, the number of members and composition of which shall be clearly stipulated. The Declaration shall also establish design guidelines governing the appearance of the site buildings, signs, lighting, landscaping, street furniture, fencing, and mechanical equipment.
- D. The Declaration shall stipulate the method and procedure by which the Declaration may be amended.
- E. The Declaration shall specify the maximum percentage of lot area which will be set forth in the approved preliminary project plan.
- F. The Declaration may also contain use restrictions which are more restrictive than the Town's Zoning provisions, but in no case shall they be more permissive.

CHARLESTON TOWN

- G. The Declaration shall set up the provisions for maintenance of all buildings, common areas, landscaping and private streets and utilities.
- H. The Declaration shall state the following: Charleston Town shall have the right, but not the duty, to require, and if necessary, perform, at the Association's expense, landscaping, maintenance, and snow removal within the common areas if the Association fails adequately to perform such. In the event Charleston Town exercises this right, the City shall be entitled to recover any associated costs and attorney fees from the Association. This section shall not be amended or deleted without the approval of the Town of Charleston.

02.0626 Lighting.

The following lighting requirements shall apply in industrial and commercial

- A. Applicants for development approval shall submit a lighting plan, which shall include a photometric analysis.
- B. Site lighting shall adequately light all parking areas, walkways, and common areas. Site lighting shall be designed and/or shielded to prevent glare on adjacent properties.
- C. Lighting fixtures on private property shall be architectural grade and consistent with the architectural theme of the development.
- D. Lighting fixtures on public property shall be architectural grade and consistent with a streetlight design approved by Heber Light and Power Co.

1. Heber Power and Light Guidelines

CHARLESTON TOWN

Specifications

POST DESCRIPTION

The lighting post shall be all aluminum, one-piece construction, with a classic fluted base design and a square anchor bolt cover. The shaft shall be $\varnothing 4"$ fluted.

MATERIALS

The base shall be heavy wall, copper free, cast aluminum produced from certified ASTM 356.1 ingot per ASTM B-179-95a or ASTM B26-95. The straight shafts shall be extruded from aluminum, ASTM 6061 alloy. All hardware shall be tamper resistant stainless steel. Anchor bolts to be completely hot dip galvanized.

CONSTRUCTION

The shaft shall be double welded to the base casting and shipped as one piece for maximum structural integrity. The shaft shall be circumferentially welded inside the base casting at the top of the access door, and externally where the shaft exits the base. All exposed welds below 8' shall be ground smooth. All welding shall be per ANSI/AWS D1.2-90. All welders shall be certified per Section 5 of ANSI/AWS D1.2-90.

DIMENSIONS

The post shall be 14'-0" in height with a 13" square base. The shaft diameter shall be 4". At the top of the post, a $\varnothing 3"$ by 3" tall tenon with a transitional donut shall be provided for luminaire mounting.

INSTALLATION

The post shall be provided with four, stainless steel L-type anchor bolts to be installed on a 14" diameter bolt circle. A door shall be provided in the base for wiring access. A grounding screw shall be provided inside the base opposite the door.

FINISH

The assembly shall have a standard Holophane black finish.

LUMINAIRE

- Granville II LED Classic Utility
 - 60W 4K CCT
 - Auto-Sensing 120-277V
 - Modern Style Housing, Black Finish
 - Asymmetric Lunar Optic
 - No Trim, Spike Finial
 - Full Cover, Black
 - NEMA Twistlock Photocontrol Receptacle
 - DTL Twistlock Photocontrol
- For complete specifications see LUM_ARUE.



Anchorage Detail

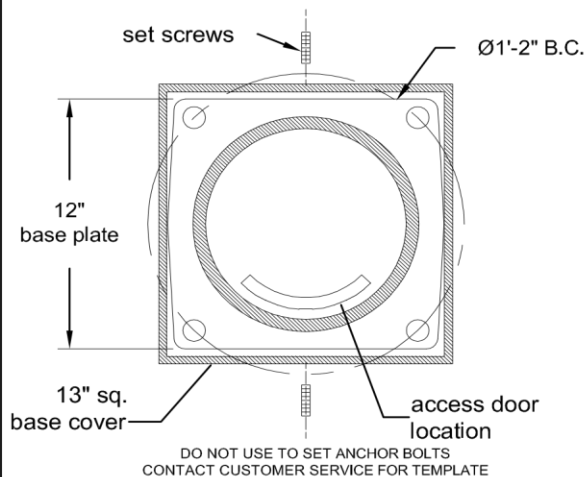

Catalog #'s:

SMA14F4J13P07ABGBK - GVD604KASMB6NSBFCVRBHBCS

Customer Signature

Date



Heber Residential

ORDER #: 2172-12-10327-2	TYPE:	DRAWING #:
REVISION: 1	30	REVISION DATE: 08/07/14
DRAWN: MAB	ORIGIN DATE: 08/05/14	TSG 008492
		PAGE: 1 of 1

CHARLESTON TOWN

- E.** Care shall be taken to ensure that no exterior lighting shines directly onto adjoining property.
- F.** Incident light at the property line shall not measure more than ten foot-candles.
- G.** Night Skies Protection. The use of outdoor lighting is often necessary for adequate nighttime safety and utility, but common lighting practices can also interfere with other legitimate public concerns. Principle among these concerns is:
1. The degradation of the nighttime visual environment by production of unsightly and dangerous glare.
 2. Lighting practices that produce excessive glare and brightness that interferes with the health and safety of Charleston's citizens and visitors.
 3. Unnecessary waste of energy and resources in the production of too much light or wasted light.
 4. Interference in the use or enjoyment of property that is not intended to be illuminated at night by light trespass, and the loss of the scenic view of the night sky due to increased urban sky-glow; and,
 5. The impact of inappropriately designed outdoor lighting that disrupts nocturnal animal behavior, particularly migrating birds and other species.
- H.** All outdoor lighting fixtures shall be installed in conformance with the provisions of this Division and the applicable Building Codes currently in effect in the Town under appropriate permit and inspection.
- I.** Light Trespass Standard. All light fixtures, including security lighting, shall be located, aimed and shielded so that the direct illumination from the fixture shall be confined to the property boundaries of the source.
- J.** Shielding Configurations:

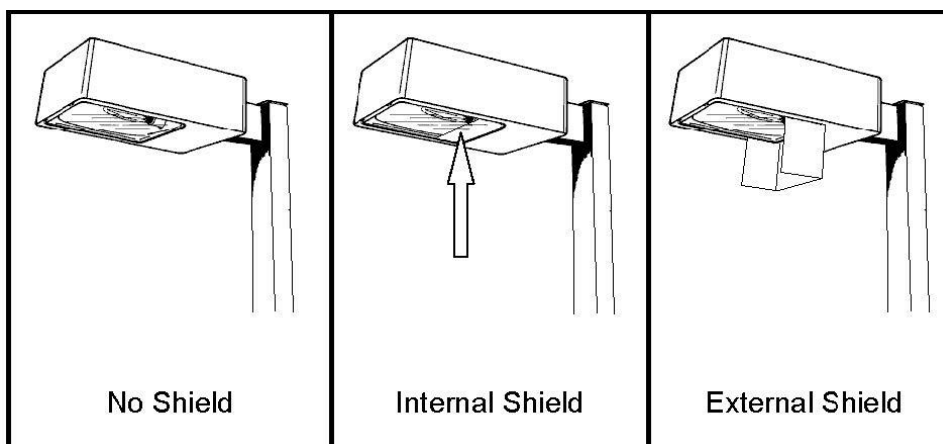

- K.** Motion sensing light fixtures. Motion sensing light fixtures shall be fully shielded.
- L.** Neon building lighting neon building lighting is not allowed.
- M.** Architectural/landscape lighting. Architectural lighting used to illuminate the wall of a building or landscape lighting used to illuminate trees or other landscape elements is

CHARLESTON TOWN

permitted subject to the following: Architectural and landscape lighting that is directed upward or downward onto a wall, tree or other landscape feature shall be included in the Total Outdoor Light Output for the site.

- N. Emergency lighting. Emergency lighting that is only turned on in the event of a power failure or when an alarm is activated is permitted in all lighting zones and is excluded from the total lumen calculations for the site.
- O. Use of Mercury Vapor or Metal Halide Light Fixtures. No new mercury vapor or Metal Halide outdoor light fixtures shall be installed in new construction after January 1, 2016.
- P. Service Station/Convenience Store Canopy Lighting.
 - 1. All light fixtures mounted on or recessed into the lower surface of service station canopies shall be fully internally shielded and utilize flat lenses. Such shielding must be provided by the fixture itself; shielding by surrounding structures such as canopy edges is not permitted.
 - 2. Total Under-Canopy Output. The total light output used under service station canopies, defined as the sum of all under-canopy initial lamp outputs in lumens, shall not exceed 40 lumens per square foot of canopy.
 - 3. All lighting mounted under the canopy, including but not limited to light fixtures mounted on or recessed into the lower surface of the canopy and any lighting within signage (but not including any lamps mounted within the pumps and used to illuminate information indicating such items as the total cost of fuel pumped and price per gallon), shall be included in the Total Outdoor Light Output for the site.

02.0627 Phasing of Commercial, Industrial or Residential Development Plans

Applicants seeking development approval of a phased project shall submit for review at the time of preliminary plat or site plan approval a project phasing plan. Development shall be in accordance with the project phasing plan unless the Town Council approves a revised project phasing plan. Unless otherwise approved by the Town Council, each phase will include all associated improvements, including landscaping. All improvements required for each approved phase shall be completed before a subsequent phase shall be permitted to begin construction.

02.0628 OFF-STREET PARKING, ACCESS AND LOADING

This chapter is established to provide minimum standards for parking stalls, parking areas and access to and from developments. The following objectives should guide the implementation of these standards:

- Promote traffic circulation in and between developments.
- Minimize access points on collector and arterial streets.
- Mitigate environmental impacts of parking areas.
- Enhance safety and efficiency in vehicular and pedestrian movement.
- Encourage convenience and efficiency of parking areas.
- Encourage aesthetic design of parking and loading areas.

CHARLESTON TOWN

02.0629 Off-Street Parking, Access and Loading Standards:

- A. All new development, except where privately controlled access is approved by the Town Council, shall have access to a public street. Any development requiring site plan or plat approval shall meet the minimum street and access requirements of this chapter and all Town Engineering Requirements, which may include a traffic study as may be required by the Town Engineer. The Planning Commission shall review all proposed plans for access as part of the site plan and subdivision review. Variations from minimum standards may be recommended by the Town engineer.

- B. Streets and related improvements shall be designed, constructed and dedicated according to state and/or Town standards and when rationally related to the impact of the project on the Town's transportation system, including the road and bridge design and construction standards, and according to the alignments and design widths established by the Town.

- C. Accesses shall be designed with right angles to public streets. Driveways and streets shall be aligned with other driveways and streets as required by the Town engineer.

- D. Reciprocal and shared driveways shall be required as deemed necessary by the Town engineer. All such driveways and accesses shall be documented with easements and/or agreements recorded with the Wasatch County recorder.

- E. The number and spacing of access points and their locations shall be determined by: (1) UDOT, based on the US-189 (SR113 to US-40) Corridor Preservation Agreement dated (16 Mar 2016), if on US-189, (2) UDOT if on SR-113 and (3) the Town Engineer, if on a Town street to be governed by the Town’s minimum standards listed below. The Town engineer, based upon good engineering judgment, may allow a modification to these minimum standards. Distances shall be measured from the edge of the pavement (where no curb exists) or back of the curb of a driveway and from the existing or planned right of way line of a street. Intersecting streets on opposite sides of collector or arterial streets shall be aligned as required by the Town and the US-189 Corridor Preservation Agreement respectively. Double frontage lots may be accessed only from neighborhood streets, not from collector or arterial streets.

Maximum number of accesses to each lot		1 per 300 feet of street frontage, or part thereof, or less if shared access is required
Minimum access and/or street separation on collector street		100 feet
Minimum access separation on neighborhood street		20 feet

CHARLESTON TOWN

Minimum access and street separation on neighborhood street		30 feet
Minimum access width (2-way, 2 lane)		24 feet
Maximum access width (2-way, 2 lane)		30 feet
Minimum access width (1-way, 1 lane)		12 feet
Maximum access width (1-way, 1 lane)		15 feet
Maximum access width with minimum 4 foot wide landscaped median		40 feet
Minimum access width, single-family residence		12 feet
Maximum access width, single-family residence		30 feet

- F.** All internal driveways and access aisles shall have minimum widths of twenty-four feet (24') for two-way driveways and twelve feet (12') for one-way driveways which are clearly marked as such.
- G.** Loading and delivery areas shall be accessed by paved driveways which are separated from customer parking and pedestrian areas. No loading area shall be provided in the public right of way. Loading areas shall be located at the rear or sides (not street sides) of buildings and shall be of adequate size to accommodate the backing and maneuvering of delivery vehicles. Loading areas shall be screened from view of public streets and adjacent properties with fences, walls, landscaping or architectural features consistent with the building. Drive-up windows may be located on the street side of a building only if:
1. This arrangement provides for optimum traffic circulation and safety.
 2. This arrangement mitigates impacts to neighboring properties.

CHARLESTON TOWN

3. The architectural appeal of the building is maintained on the drive-up window side; and
 4. Additional landscaping and/or architectural features are used to enhance the aesthetic appeal of the development.
- H.** Defined pedestrian access shall be provided to connect developments, buildings, streets and parking areas. Sidewalks over which parked vehicles may overhang shall be at least six feet (6') wide on single parking rows and eight feet (8') wide between double rows. Sidewalks adjacent to parking stalls shall be at least four inches (4") higher than parking surfaces.
- I.** If approved by the Town, cash may be paid to the Town in the amount of one hundred twenty five percent (125%) of the estimated cost of required street and related improvements to defer construction of improvements to existing roads and related improvements or portions thereof which are designated for widening or realignment in the transportation master plan and are rationally related to the impact of the proposed development on the Town transportation system. If street improvements are postponed, the developer shall dedicate the right of way as required in subsection B of this section.
- J.** Pedestrian walkways, at least six feet in width, shall be provided along all improved Town streets in the C-1 Commercial Zone. Pedestrian walkways along State Highways shall be as required/approved by UDOT.
- K.** All pedestrian walkways and vehicular parking and access areas shall be paved with masonry, concrete or asphalt and maintained in good condition. Pavement markings for parking stalls, disabled persons, crosswalks, travel lanes, driveways, fire lanes and loading areas shall also be maintained in good condition.
- L.** Access shall be designed to facilitate safe and efficient vehicle and pedestrian movement. Additional requirements may be placed on developments to accommodate emergency vehicle access or to enhance traffic circulation and safety.
- M.** Access to developments shall accommodate landscaped islands and trees as described in the landscape requirements of this title.
- N.** Any lighting used to illuminate off-street parking facilities or vehicle sales areas shall be so arranged as to reflect the light away from the adjoining premises in any residential zone.
- O.** At the time a building permit is requested for any building or structure, or at the time the use of land is changed which requires additional off-street parking space, a plot plan shall be submitted showing the location and layout of such required space along with access aisles, roadways, curbs and curb cuts. The Zoning Administrator shall disapprove such plans if he finds that the required spaces are not usable for standard-sized automobiles or do not comply with the requirements for off-street parking as set forth in this Ordinance.
- P.** For every building having a gross floor area of five thousand (5,000) square feet or more to which goods, material, merchandise, or supplies are received or distributed by

CHARLESTON TOWN

vehicle, there shall be provided at least one off-street loading space. One (1) additional loading space shall also be provided for each additional twenty thousand (20,000) square feet of gross floor area of such building or for each vehicle which must be loaded or unloaded at the same time, whichever requirement is greater. Each required off-street loading space shall be not less than ten (10) feet in width, twenty-five (25) feet in length, and fourteen (14) feet in height.

- Q.** The required off-street parking and loading facilities shall be a continuing obligation of the property owner so long as the use requiring vehicle parking or vehicle loading facilities continue. It shall be unlawful for an owner of any building or use to discontinue or dispense with the required vehicle parking or loading facilities without providing other vehicle parking or loading areas which meets the requirements of this Ordinance.
- R.** All commercial, industrial and institutional developments shall have permanent, clearly marked parking spaces designed and constructed according to the provisions of this chapter. Any development requiring a site plan or plat approval shall meet the minimum parking requirements of this chapter and be approved by the Town. Planning Commission shall review and approve all proposed plans for parking.
- S.** All parking areas shall be paved with concrete or asphalt and shall be maintained in good condition. Striping shall also be maintained in good condition to clearly define parking stalls, driveways, markings for disabled persons, crosswalks, pedestrian and travel lanes, loading areas and fire lanes.
- T.** Parking areas shall be constructed to accommodate drainage and access requirements of Town ordinances. The required off-street parking facilities shall be the continuing obligation of the property owner as long as the use requiring said parking facilities is continued. Parking facilities existing at the time of adoption of this chapter which are nonconforming with the provisions of this chapter may continue, provided, that the use of the premises is not replaced by one requiring additional parking stalls. Any expansion or intensification of the use of the property shall be accompanied by compliance with the parking requirements of this chapter.
- U.** Parking facilities shall be provided on the same lot as the use for which the parking facilities are required, except for approved common or off premises parking facilities.
- V.** Common or off premises parking facilities are not permitted in agricultural or residential zones, except as allowed by the Planning Commission and a conditional use permit granted by the Town Council.
- W.** Off-premises parking facilities may be used to satisfy the requirements of this chapter with Town Planning Commission approval; provided, that all provisions of this chapter continue to be met.
- X.** Common parking facilities for more than one use may be used to satisfy the requirements of this chapter. The minimum number of parking spaces for the combined uses on the lot

CHARLESTON TOWN

shall be the total of the parking spaces required for the individual uses.

- Y.** No parking area back up space shall be provided in the public right of way, except for approved on street parking.
- Z.** All parking areas and driveways shall be bordered with concrete curb walls or other approved barriers except where adjacent to future phases of development as determined by the Town Planning Commission.
- AA.** Parking structures shall be considered buildings for purposes of the yard requirements of this title.
- BB.** The following minimum design standards shall apply to parking stalls:

Stall width		9 feet
Disabled stall width		9 feet with adjacent 5-foot-wide access aisle on both sides of the stall
Stall depth		20 feet
Stall depth when minimum 6 foot (or 8 feet for double rows) wide curbed landscape planter or sidewalk is used for overhang (minimum 4 feet of planter or sidewalk must remain clear)		18 feet
Parallel stall length		27 feet

- CC.** All parking areas shall be lit. A lighting plan shall accompany all parking area proposals. Lighting shall be arranged or shielded to prevent glare on adjacent residential or agricultural properties.
- DD.** Parking stalls required for a particular use shall be located within a four-hundred-foot (400') radius of said use. Parking areas may not be divided from the uses they serve by public streets.
- EE.** Parking areas in all developments shall be designed to accommodate emergency access as determined by the Planning Commission.
- FF.** Parking areas in residential developments shall be designed to accommodate recreational vehicles including watercraft, campers, motor homes, snowmobiles, all-terrain vehicles and travel trailers.

CHARLESTON TOWN

GG. Parking areas shall accommodate landscaped islands and trees as described in the landscape requirements of this title.

HH. Parking Ratios. The following ratios shall be used in computing the number of parking stalls required for the uses listed. The Planning Commission may determine the requirements for individual developments if a use is not listed or under unusual circumstances in which a greater or lesser number of parking stalls is justified.

<u>Use Required</u>	<u>Spaces</u>
Animal or Agricultural retail or services	1 per employee plus 1 per 500 square feet of floor area
Beauty and hair salons	3 per chair
Bowling alley	4 per lane
Car wash, automatic or self-serve	1 per bay for cleaning or drying plus 2 stacking per bay
Car wash or fast lube	1 per employee at maximum shift change plus 4 stacking per bay
Churches, synagogues and temples	1 per 3 seats in fixed seating area plus 1 per 100 square feet of floor area of additional areas
Convenience stores and gas stations	1 per 150 square feet of floor area
Daycare centers and preschools	1 per 300 square feet of floor area
Dry cleaners and laundries	1 per 200 square feet of floor area
Emergency services, medical clinics and treatment	1 per 200 square feet of floor area
Golf course	2 per hole plus 1 per 200 square feet of floor area
Golf driving range	1 per tee plus 1 per 200 square feet of floor area
Government	1 per 400 square feet of floor area
Group, disabled or nursing home	1 per 3 beds plus 1 per employee
Home occupations with customers on premises in addition to standard residential requirements	1 per dwelling
Horseback riding and stables	1 per horse or stable

CHARLESTON TOWN

Hospitals		2 per bed
Hotels and motels		1 per room
Libraries, museums and art galleries		1 per 300 square feet of floor area
Manufacturing, processing and assembling		1 per 800 square feet of floor area or 1 per employee at maximum shift change
Miniature golf, skateboard parks, water parks and skating rinks		As determined by the Town on a case-by-case basis
Mortuaries and crematoria		1 per 3 seats in assembly area
Motor vehicle and other light repair		1 per 100 square feet of floor area plus 1 per employee at maximum shift change
Motor vehicle or other heavy repair		1 per 200 square feet of floor area plus 1 per employee at maximum shift change
Motor vehicle sales or rental		1 per 400 square feet of floor area
Movie theaters		1 per 3 seats
Office		1 per 300 square feet of floor area
Outdoor markets, garden nurseries and greenhouses		1 per 400 square feet
Post office		1 per 200 square feet of floor area
Recreation, amusement, entertainment and other assembly		1 per 4 seats if seating is known or 1 per 100 square feet of floor area
Residential:		
Single-family dwelling		2 per dwelling
Two-family dwelling		4 per dwelling
Restaurants		1 per 100 square feet of floor area or 1 per 4 seats
Restaurants with drive-up		1 per 100 square feet of floor area or 1 per 4 seats plus 5 stacking
Retail sales or rental		1 per 200 square feet floor area

CHARLESTON TOWN

Schools:		
Elementary and secondary		5 per classroom
High school		15 per classroom
Colleges, universities and vocational schools		1 per 100 square feet of floor area
Social, fraternal, professional and other meeting halls		1 per 300 square feet of floor area
Stadiums		1 per 4 seats
Swimming pools		1 per 4 persons based on capacity
Telemarketing, wholesale (no customers on premises)		1 per employee at maximum shift change
Warehousing, distribution and storage		1 per 800 square feet of floor area or 1 per employee at maximum shift change
Weight reduction, health and fitness centers		1 per 200 square feet of floor area
Wholesale with customers		1 per 400 square feet of floor area

II. Parking and Access for Disabled Persons. All buildings and uses on the site shall be equipped with appropriate means of access for disabled persons. Said access shall meet requirements of the building code. Standards of the Americans with disabilities act should be followed to provide safe and convenient access for the disabled. Failure to comply with any of the requirements of the Americans with disabilities act does not constitute a violation of this chapter.

JJ. Landscaping Required Surrounding Off-street Parking Space. All off-street parking lots designed for five or more vehicles shall be bordered by a curb and/or a landscaped strip at least eight (8) feet in width.

KK. Off-street Loading Space Required For every building having a gross floor area of five thousand (5,000) square feet or more to which goods, material, merchandise, or supplies are received or distributed by vehicle, there shall be provided at least one off-street loading space. One (1) additional loading space shall also be provided for each additional twenty-thousand (20,000) square feet of gross floor area of such building or for each vehicle which must be loaded or unloaded at the same time, whichever requirement is greater. Each required off-street loading space shall be not less than ten (10) feet in width, twenty-five (25) feet in length, and fourteen (14) feet in height.

CHARLESTON TOWN

02.0630 Conditional Use Permits

The purpose of this chapter is to provide for the establishment of certain uses designated as "conditional uses" in the various zoning districts. Conditional uses are not allowed by right but may be allowed if conditions are applied which, in the judgment of the Town Council, would mitigate possible conflicts or detriments that may arise by introducing a conditional use into a zoning district. Conditional uses are generally considered to be compatible with the permitted uses in individual zones if adequate mitigation can be accomplished. Conditional use permits will allow proper integration of certain uses in the Town which may only be suitable in specific locations, and which may have potentially detrimental characteristics if not properly designed, located and conditioned. This chapter prescribes the criteria and process for evaluating, establishing and conducting conditional uses in the Town. Conditional uses must be approved if reasonable conditions are proposed or can be proposed.

02.0631 Conditional Use Permit Required.

A conditional use shall not be established or commenced without a conditional use permit for which approval of the Town Council has been obtained in conformance with the requirements of this chapter and other pertinent laws and ordinances. Unless otherwise specified by the Town Council and subject to the provisions relating to commencement of action, amendment or revocation of a conditional use permit, a conditional use permit shall be of indefinite duration and shall run with the land, except for home occupations, temporary or seasonal uses, uses proposed in leased or rented property or other uses as specified by the Town Council. The Town Council may place conditions on the approval of a conditional use permit relating to the following or other factors to ensure the public health, safety, welfare, and economic viability, to enforce the zoning and development ordinances of the city, and to implement the general plan of the city:

A. General Standards for Conditional Use Approval:

An applicant for a conditional use approval shall provide, within the application, information to clearly demonstrate to the Town Council compliance with the following in addition to any other specific requirements of this ordinance attached to the conditional use applied for:

1. **General Welfare Standard.** The establishment, maintenance or conducting of the use for which a use permit is sought will not, under the particular case, be detrimental to the public welfare or injurious to property or improvements in the neighborhood.
2. **Nuisance Standard.** Any use found to be objectionable or incompatible with the character of the city and its environs due to noise, light, traffic, dust, odors or other undesirable characteristics may be prohibited.
3. **General Plan Consistency Standard.** To obtain a conditional use permit, the applicant must generally show that the contemplated use is compatible with the Town's land use policies in terms of the general plan and zoning ordinances, and that such use would be essential or desirable to the public convenience or welfare, and will not impair the integrity and character of the zoned district or be detrimental to the public health, safety, morals or welfare.

CHARLESTON TOWN

B. General Standards for Imposing Conditions to Approvals:

After a public hearing, the Town Council shall decide whether to grant or deny the proposed conditional use permit. The Town Council shall record its decision in writing and shall recite the findings upon which the decision is based. The Town Council may approve and/or modify a conditional use permit application in whole or in part, with conditions, only if all of the following findings are made:

1. The proposed use is conditionally permitted within the zoning ordinance, and would not impair the integrity and character of, the intended purpose of the subject zoning district and complies with all of the applicable provisions of this ordinance.
2. The proposed use is consistent with the general plan.
3. The approval of the conditional use permit for the proposed use is in compliance with the requirements of state, federal and Charleston Town or other local regulations.
4. There will be no potential significant negative effects upon environmental quality and natural resources that could not be properly mitigated and monitored.
5. The design, location, size, and operating characteristics of the proposed use are compatible with the existing and future land uses within the general area in which the proposed use is to be located and will not create significant noise, traffic, or other conditions or situation that may be objectionable or detrimental to other permitted uses in the vicinity or adverse to the public interest, health, safety, convenience, or welfare to the city;
6. The subject site is physically suitable for the type and density/intensity of the use being proposed; and
7. There are adequate provisions for public access including internal and surrounding traffic flow, water, sanitation, and public utilities, and services to ensure that the proposed use would not be detrimental to public health and safety.

C. Imposition of Conditions to the Approval:

The Town Council may impose conditions on the requested use which are additional to any conditions which are specifically listed in conjunction with all conditional uses or special exceptions prescribed within this ordinance. All conditions imposed shall meet the following criteria:

1. The condition is within the Town's police powers.
2. The condition must substantially further a legitimate public purpose.
3. The condition must further the same public purpose for which it was imposed.
4. The property owner may not be required to carry a disproportionate load in furthering the public purpose; and
5. Dedication of land and other contributions as conditions of approval must be "reasonably related" to the use of the property for which the conditional use

CHARLESTON TOWN

permit is requested. There must also be a "rough proportionality" between the extent of the condition and the particular demand or impact of the project. In addition, a performance bond cannot be required for the installation of public improvements that are not reasonably related to the property use. The conditions which are imposed on a conditional use permit must be expressly attached to the permit and cannot be implied. For example, if a conditional use permit contains language that restricts a building's height to 25 feet and requires the developer to submit and obtain Town Council approval of a landscaping plan, among other things, the permit itself does not imply a height limitation on trees within the development. Mitigating conditions that may be imposed include, but are not limited to the following areas:

- a. Landscaping.
- b. Access, loading and parking.
- c. Architecture and signs.
- d. Drainage and utilities.
- e. Sanitation.
- f. Fencing and screening.
- g. Setbacks.
- h. Natural hazards.
- i. Public safety.
- j. Environmental impacts.
- k. Hours and methods of operation.
- l. Dust, fumes, smoke, odor.
- m. Noise, vibrations.
- n. Chemicals, toxins, pathogens, gases.
- o. Heat, light, radiation.

D. Denial of a Conditional Use Permit:

The following findings or others may, in the judgment of the Town Council, be cause for denial of a conditional use permit application:

1. The proposed use is unlawful.
2. The proposed use would negatively affect property values, the quality of life or the welfare of citizens and property owners in the community.
3. The proposed use would create or pose a nuisance, conflict or hazard relating to noise, vibration, light, electrical or electronic interference, traffic, odor, fumes, dust, explosion, flooding, contamination or other negative effect to the adjoining properties or the community in general.
4. The proposed use is found to be incompatible or architecturally inconsistent with neighboring uses.
5. Conditions of approval could not reasonably mitigate the negative impacts of the proposed use.

CHARLESTON TOWN

6. The proposed use is not economically viable, or the proposed use would negatively affect the economic viability of the neighboring properties or the city in general.

E. Site Plan Review for Conditional Use Permit: A conditional use permit application may only be approved in conjunction with a site plan as described and outlined below:

1. A site plan application shall be prepared and submitted with the Conditional Use Permit application for new developments for which conditional use approval is required according to the requirements of this chapter.
2. A conditional use may not be initiated, established, constructed or conducted without site plan approval as required in this chapter. A conditional use may not be commenced until all required improvements are completed and all conditions are satisfied.
3. A conditional use permit application may be considered by the Town Council without a site plan under one or more of the following conditions:
 - a. The use is temporary.
 - b. The use requires no onsite parking, building or permanent site improvements or alterations.
 - c. To determine if a use is appropriate for a particular location before a site plan application, if necessary, is prepared.

F. Application for Conditional Use Permit: The following shall be submitted when application is made for a conditional use permit:

1. Application form, fee and owner's or agent's affidavit.
2. Description of proposed use.
3. Mailing labels and postage for owners of subject property and owners within one thousand (1,000) feet of the subject property.
4. Wasatch County plat of subject property and adjacent properties within one thousand (1,000) feet.

G. Conditional Use Permit Application Review: Once the complete and accurate conditional use permit application is submitted, the request will be scheduled on the Town Council agenda. The Town Council will hold a public hearing and after hearing public comment, approve with conditions, postpone action, or deny the conditional use permit application. Any person aggrieved by the decision of the Town Council may appeal the decision to the Land Use Appeal Authority but no later than fourteen (14) days from the Town Council's decision.

CHARLESTON TOWN

1. **Business License.** In addition to a Conditional Use Permit, a business License may be required when the operation of a business is the intent of the Conditional Use Permit application.
2. **Timely Commencement.** A conditional use and required improvements for said use must be commenced within one year from the date of approval. If a building permit or business license is not obtained, if impact fees are not paid or if the foundation of a main building is not installed within one year of the date of approval of the conditional use permit application, the conditional use permit shall be null and void.
3. **Compliance Required.** A conditional use may be commenced only upon completion of all plan improvements as stipulated in the accompanying site plan. The conditional use permit will be conducted in conformance with approved plans and conditions. Application to amend a conditional use permit may be requested by following the application procedures in this chapter. A conditional use permit may be revoked by the Town Council after a public hearing if requested by a neighboring property owner or if it is shown that one or more of the following conditions exist:
 - a. The use is conducted prior to completion of all required improvements and conditions.
 - b. The use is established or conducted contrary to any of the approved plans or conditions.
 - c. The use is conducted contrary to local, state or federal laws.
 - d. The use is creating a nuisance or hazard.
 - e. A business operated under a Conditional Use Permit fails to maintain a current business license with the Town.

02.0632 Home Occupation Business Licenses

02.0632.01 Home Occupations Generally

The purpose in regulating commercial activities in residential zones is to maintain the neighborhood's residential character and to ensure compatible uses, which do not add significant traffic, noise, outside storage, or other environmental conditions such as dust or odors. Unless specifically exempted below, home occupation businesses are required to obtain approval under this Chapter and maintain a current Town business license.

02.0632.02 Home Business Licensure:

The following businesses are required to apply for and obtain approval from the Town under the requirements of this Chapter and then, if approved, to maintain a business license thereafter:

1. In-home child or adult care and preschool business.
2. Businesses that require or attract more than twelve vehicle trips per day, including but not limited to package delivery, client visits, and employee trips.

CHARLESTON TOWN

3. Businesses that have one or more employees who live outside of the residence but work in the home.
4. Any business that is required to have a fire inspection; and
5. Any business that is required to obtain a license from another government agency, such as the Department of Health.

The following home occupation businesses are exempted from licensure, are not subject to the approval requirements and are not required to obtain a license under this Chapter to conduct a business if:

1. The business has a lack of contacts, i.e., no service is provided or product sold within the Town more frequently than four times a year; or
2. The business is specifically exempted from municipal business licensing and fees by the laws of the United States or the State of Utah; or
3. The person is acting as a trustee, receiver, or other public officer pursuant to judicial order or supervision; or
4. The business is a fruit or vegetable stand that sells produce grown solely on the seller's property which is located in the Town; or
5. The person conducting the business is under the age of eighteen and is conducting the business as a part time hobby or occupation and is not engaged in such activities as the principal means of that person's support; or
6. The business consists of mere delivery in the Town of goods or trade services purchased at a regular and licensed place of business outside the Town; or
7. The combined offsite impact of the home occupation business and primary residential use materially exceeds the offsite impact of the primary residential use alone as per Section 10-1203-7 ii b of the Utah State Code.

Whether or not a business license is required under this Chapter, all home and premises occupation businesses are required to meet all applicable requirements of the Town of Charleston, State of Utah and Federal laws. Any business that wishes to be issued a Town home occupation business license, even though not otherwise required to by this ordinance, is required to apply under the provisions of this Chapter.

02.0632.03 Prohibited Activities As A Home Occupation Business

The following activities, including any similar activities, are prohibited in association with home occupation:

1. Mortuary, crematorium, columbarium, mausoleum.
2. Animal hospitals or veterinary services.
3. Clinic, dental office, medical office, chiropractic office, or hospital.
4. Junkyard, auto wrecking yard, or salvage yard.

CHARLESTON TOWN

5. Storage, service or repair (including body work or spray finishing), sales or rental of the following: automobiles, recreational vehicles, watercraft, aircraft, ATV or other motorized vehicles that are not registered to a resident of the dwelling or to a son or daughter, sibling, parent, grandparent, or grandchild or a resident of the property.
6. Fitness or health spa facility.
7. Use of specified chemicals, pesticides and flammable/combustible materials, and including any other process or business where current adopted Building and Fire Codes would require and Operational Permit.
8. Continuous retail sales of products. Occasional sales of products or other articles is permitted where the dwelling serves as an office for a person regularly engaged in retail sales outside the dwelling, or where such occasional sales are incidental to and not the primary purpose of the home occupation.
9. Number of vehicular stops/or visits that would exceed 12 per day.

02.0632.04 Requirements Specific To Home Occupation Business Licensure:

DEFINITION AND PURPOSE:

A home occupation is any business or income producing activity conducted from a residential property. The home occupation provisions are intended to provide opportunities for minor in-home businesses that do not require the facilities of or have the impacts of larger concerns. Many types of businesses are allowed: provided that they meet all of the provisions of this Chapter. Home occupations do not include occasional baby-sitting at the dwelling, which would not be classified as a daycare or preschool operations. Home occupations are considered accessory uses in residential and agricultural zones. Home occupations will have no significant impact on the neighborhoods in which they are located and are considered secondary and clearly incidental to and compatible with residential neighborhoods.

The following requirements shall apply to any home occupation:

1. Home occupations shall maintain the residential character of the dwelling, lot and neighborhood by complying with the following requirements:
2. The combined area of all home occupation activities, including operation, office space, and storage space, shall occupy not more than thirty-five percent of the floor area of the primary dwelling or one thousand square feet, whichever is less, including areas used for the business within an attached garage.
3. No business displays or advertising shall be visible from the exterior of the premises, except as permitted in Chapter 02.0622 Signs.
4. Business activities involving pedestrian or vehicular traffic shall be conducted only between the hours of 7:00 A.M. and 9:00 P. M.
5. Business activities shall be conducted entirely within the space of a dwelling unit except that activities may be conducted outdoors that are limited to children's play (Daycare uses), recreational instruction (swimming, tennis, etc.).
6. Space utilized for a home occupation shall have been properly permitted and shall have been issued a certificate of occupancy by the Town.
7. Storage: Outside storage, visible from the public right-of-way or adjacent properties, which exceeds what is customary for single-family residence in the vicinity, is prohibited.

CHARLESTON TOWN

8. Commercial Vehicle: Only one such vehicle associated with the home occupation business may be parked on a residential lot. A commercial vehicle parked or stored on a residential lot must be owned or apportioned by an occupant who resides at the residence. This vehicle must comply with all residential parking requirements contained within this code.
9. Delivery Vehicles: The receipt or delivery of merchandise, goods, or supplies for use in a premises occupation shall be limited to vehicles with gross vehicle weight rating (GVWR) of 23,000 pounds or less.
10. More than one home occupation may be associated with a residential dwelling, provided that all home occupations associated with a residential dwelling shall collectively comply with the regulations of this Chapter.
11. If the applicant is leasing the property, written proof must be provided to the Town that the applicant has the landowner's permission to operate the home occupation business.
12. The Town may place additional restrictions on a home occupation relating to hours of operation, parking, traffic, deliveries or other matters, as it deems necessary to mitigate impacts on the neighborhood and the Town in general.

02.0632.05 Preschools-Additional Requirements

Preschools may be conducted as home occupations in accordance with provisions of this Chapter with the following and other conditions as determined by the Planning Commission:

1. Maximum two sessions per day. Sessions shall be a maximum of three hours in length.
2. Maximum ten per session.
3. Students' ages shall be three, four or five years old.
4. Days and hours of operation shall be provided for review.
5. All life safety and building codes shall be met and a building permit, if necessary, shall be obtained for remodeling.
6. All other requirements of this Chapter and other local, state and federal laws shall be met.

The following items shall be submitted to the Town Clerk's office in applying for a new or amendment to a home occupation business license:

1. Application forms as provided by the Town and the associated fee. As determined by the Town Council.
2. Detailed description of the Nature of the home occupation and information as requested in the application.
3. Sketch of the floor plan of the residence.
4. A list of any equipment to be used in association with the home occupation business.
5. A list of any chemicals or hazardous materials to be used in association with the home occupation business.
6. Hours of operation and the number of customers, vehicle trips and deliveries anticipated to be made each day.
7. Other government approvals required for conducting the premises occupation.

CHARLESTON TOWN

8. Proposed remodeling needed to conduct the home occupation and whether a Town building permit will be required.
9. Signed affidavit by the applicant that all requirements and conditions of the Town will be followed, if approved.
10. Mailing labels and postage for owners of properties within one-thousand feet of the lot or parcel.

02.0632.06 Home Occupation Business License Application Review Procedure:

The Town Clerk's office shall mail a written notice informing the neighboring property owners within one thousand (1000) feet of the parcel for which the home occupation business license is being proposed. Notified neighbors shall have fourteen days from the postmark of the notification to file with the Town any information asking to be considered by the Planning Commission. Town staff will review the premises occupation license application and when it is determined that the application is complete, the application will be scheduled for the next regular Planning Commission meeting following the close of the comment period for the public hearing. The Planning Commission may approve the application if all requirements are met and if no additional information conflicting with the provisions of this Chapter has been filed with the town or is brought up at the public hearing.

Home occupation business licenses are not transferable to new property owners, and new application must be made by the new owners and approved by the Town under this Chapter before the business shall continue.

02.06032.07 Home Occupation Business License Application Appeal Procedure:

If the Planning Commission finds that certain conditions cannot be met or that the proposed premises occupation is inconsistent with the definition and purpose of this Chapter, the application shall be denied. The Town Clerk's office shall provide written notice of the Planning Commission's decision to the applicant and to all individuals who provided written responses to the original notice.

The applicant or an affected property owner may appeal against the Planning Commission's decision for a public hearing before the Town Council within fourteen days of the decision rendered by the Planning Commission. Costs of notification of the public hearing before the Town Council shall be borne by the appellant.

02.0632.08 Home Occupation Business License Renewal

Annually, within 45 days of expiration of the existing license, the home occupation business license holder shall reapply for renewal of the business license. The Town Clerk may renew the business license if no unresolved complaints are pending or if no revocation proceedings are in process, as described in Section 02.0632.11.

02.0632.09 Revocation Of A Home Occupation Business License:

The Town Council may revoke a home occupation business license, if it is shown that one or more of the following conditions exist:

1. The use is conducted prior to completion of all required improvements and conditions.
2. The use is established or conducted contrary to any of the approved plans or conditions.
3. The use is conducted contrary to local, state, or federal laws.

CHARLESTON TOWN

4. The use is creating a nuisance or hazard.

Notice of the intent of the Town Council to revoke a home occupation business license shall be sent to the license holder by certified mail. Within fourteen days of the date of the receipt of the notice, the license holder may request a public hearing and may present evidence to dispute the Town Council's decision. Property owners within 1,000 feet of the home business shall be notified, at the Town's expense, of the public hearing in the same manner as required in Section 02.0632.06.

02.0634 Small Lots

Where a parcel of land at the time of the adoption of this Ordinance is at least one and eight-tenths (1.8) times as wide and one and eight-tenths (1.8) times as large in area as required for a lot in the zone, the Town Council may permit the division of a parcel into two lots, provided:

- A. Such division will not cause undue concentration of buildings.
- B. The characteristics of the zone in which the lot is located will be maintained.
- C. In the opinion of the Town Council, values in the area will be safeguarded.

02.0635 Utility Buildings and Structures Permitted

Water, sewer, and electric utility buildings and structures may be constructed in all zones subject to the approval of the Town Council. The Town Council may require conditions which are reasonably necessary to protect surrounding property values and residential amenities.

02.0636 Dwelling Sites to have Frontage on a Public Street

Except as otherwise provided for in this Ordinance, at least one side of each lot used as a dwelling site shall abut upon a street which has been designated or dedicated for public use. Length of such abutting side, measured at the setback line, shall be at least as great as the width required for dwelling sites in the zone in which such dwelling site is located.

02.0637 Uses Prohibited in Zones Unless Expressly Permitted

Uses of land which are not expressly permitted within a zone are prohibited therein, except, as may be permitted by action of the Town Council pursuant to their express authority under the terms of this Ordinance. The Town Council shall not permit a use within a zone which is not expressly permitted by the terms of this Ordinance unless it can be shown that the use is similar to other uses permitted in the zone. Where the Town Council determines a use to be similar, such use shall thereafter be deemed to be a permitted use as if it were listed therein on the effective date of this Ordinance.

02.0638 Moved Buildings

No residential, commercial, or industrial building that has had prior use shall be moved within the Town, without an application being filed therefore with the Zoning Administrator. Said application shall contain the following information:

CHARLESTON TOWN

A. Location and address of the old and new site.

1. Plot plan of the new location, also showing adjacent lots on all sides of the property and indicating all structures and improvements on said lots.
2. Plans and specifications for the proposed improvements at the new location, including plans for landscaping treatment when required by the Zoning Administrator
3. Certification by the Zoning Administrator that the structure is sound enough to be moved and that the condition, location, and use of the building will comply with the Zoning Ordinance and all other applicable codes and ordinances.
4. The application must then be approved by the Town Council. Before approving said application and authorizing the issuance of a permit, the Council must find:
 - a. That the building will have no appreciable detrimental effect on the living environment and property values in the area in which the structure is to be moved.
 - b. That the building is in conformity with the quality of buildings existing in the area to which it is proposed to be moved.
 - c. That said, the building and the lot on which the building is to be located will conform to the requirements of the Zoning Ordinance and other applicable codes, ordinances, and regulations.
 - d. That its location on the lot does not in any substantial way adversely affect buildings or uses in abutting properties.
 - e. That all landscaping, walkways and masonry work about the premises and the required dedications and improvements for streets and facilities and buildings shall be provided in conformity with the standards of the Town.
 - f. That a bond or other assurance has been posted as a guarantee that the building and grounds will be improved as stipulated by the Town Council before the building is occupied and that the vacated site will be restored to a safe and sightly condition. The amount of the bond or other assurance shall be at least equal to the cost of employing a contractor to make the improvements to the buildings and premises as required by the Town Council. The requirements of this provision shall also apply to the moving of mobile homes, de-mountable homes, manufactured homes, and similar movable structures except when being moved from outside the Town into a mobile home park.

02.0639 Transitional Uses which are permitted on either portion of a lot, which lot is divided by a zone boundary line, or which is coterminous with a zone boundary line may be permitted to extend to the entire lot, but not more than one hundred (100) feet beyond the boundary line of such zone in which such use is permitted. Before a permit for such a use may be granted, however, the Land Use Appeal Authority must find that the comprehensive plan of zoning will be maintained and that a more harmonious mixing of uses will be achieved thereby.

CHARLESTON TOWN

02.0640 Bed and Breakfast Inns

Bed and Breakfast Inns as approved by the Charleston Town Council as a Conditional Use, shall be in compliance with the Zoning Ordinance and the following:

- A. Shall not exceed eight (8) guest rooms.
- B. One (1) off-street parking space shall be provided per employee, plus one space per guest room, plus two (2) spaces for the on-site resident manager.
- C. Meals may be served to residents, employees, overnight lodgers, and guests of lodgers only. No cooking will be allowed in guest rooms.
- D. Such use shall conform to all applicable health, safety, and building codes.
- E. Room rental will be limited to 30 days.
- F. Supervision by an on-site resident manager or owner shall be required on a 24-hour-a-day basis.
- G. Any commercial use shall be incidental to the Bed and Breakfast use, i.e. gift shop, etc.
- H. All facilities must collect and pay any applicable transient room tax, sales tax, and business licensing fees.

02.0641 Zoning (Land Use) Permit

A Land Use Permit is required for any accessory building not requiring a building permit. A land use permit shall be obtained prior to the construction of any accessory building for which a building permit is not required. The applicant shall submit for review and approval by the Town's Zoning Administrator an application form, lot plan showing streets, existing buildings, dimensions, easements and setbacks of the proposed accessory building and other information as needed.

02.0642 Flag Lots and Private Streets Permitted

Flag Lots and Private Streets shall be permitted when meeting the provisions of this Section.

- A. **The purpose** of a "Flag Lot" and Private Street development is to allow the development of building lots on parcels of land shaped such that it is impossible or impractical to develop lots according to normal subdivision standards.

B. Definitions

- 1. As used in this Ordinance, "Flag Lot" means a site area that is characterized by a strip of land less two hundred (200) feet wide, which provides access to the main portion of the site area from the street. Such strip of land shall be referred to as the "pole" of the flag lot.
- 2. "Private Street" means a street at least thirty (30) feet wide held in private ownership meeting all applicable requirements of the most current International Fire Code as adopted by the State of Utah.

CHARLESTON TOWN

C. Flag Lot and Private Street Requirements

Flag shaped lots or lots served by private streets may be created in any residential zone if all of the following requirements are met:

1. The pole of the flag lot or the private street shall have at least thirty (30) feet of frontage on a dedicated street, which serves as access only to the subject lot(s) or parcel(s).
2. The pole portion of the lot or the private street shall be at least thirty (30) feet in width through its entire length;
3. The creation of a flag lot or private street may not make the original parcel the flag lot or private street and resulting lot or lots are removed from nonconforming or if already nonconforming increase the nonconformity of the original parcel in required width, area, setbacks, or any other manner.
4. A pole may not be more than two hundred fifty (250) feet in length and a private street shall not be more than five hundred (500) in length and shall meet all fire code requirements for the turning around of emergency vehicles;
5. The body of the lot shall meet the lot area and lot width requirements of the applicable zone (when calculating the width, depth, or area of a flag lot, the pole or private street may not be included);
6. The pole of the lot or private street shall be hard surfaced (concrete, asphalt, or approved equal) and signage at the intersection of the private street and the public street shall indicate that it is a "Private Street".
7. A pole and/or private street shall not serve more than five (5) lots; Flag lots and lots served by private streets shall be limited to single- family dwellings.
8. Maintenance of poles and private streets shall be at the sole expense of the owner(s) of the parcel(s) within the subdivision. A note indicating this maintenance responsibility shall be placed on the subdivision plat. The minimum setbacks for the main buildings on a flag lot and lots accessed by private streets shall be defined as follows:
 - a. The Setback from any given lot line shall be at least equal to the minimum required setback on the main building on the adjacent property from that lot line (The subdivision plat shall delineate the total buildable area on each flag lot, according to these setback requirements).
 - b. Accessory and agricultural buildings for flag lots and lots accessed by private streets are permitted under the same criteria a contained in each Residential Zone section.
9. The Town's Fire Marshal, or his/her designee, shall approve the location as to whether or not existing fire hydrants are adequate for fire protection. If existing hydrants are found insufficient, then the Charleston Town Fire Marshal shall direct where the flag lot developer, at his/her own expense, shall install additional fire hydrant(s) for fire protection in order to meet the

CHARLESTON TOWN

applicable requirements of the International Fire Code. The Wasatch County Health Department shall approve the flag lot or private street subdivision and building permits for residential dwelling units for culinary water and sanitary sewer services.

02.0643 Building Height

Maximum building height in any zone shall be thirty-five (35) feet unless the Town Council approves additional building height for a permitted or conditional use. The Planning Commission shall make a recommendation regarding the request and the Town Council shall determine that the additional height is compatible with adjacent buildings and uses before approval.

02.0644 Caretaker Dwelling Requirements And Restrictions

One caretaker dwelling on each zoning parcel for the occupancy of security guards or caretakers is permitted as an accessory use in the RA-1, RA-5 zones after a principle dwelling unit has been issued a Certificate of Occupancy by the Town Building Inspector. The main dwelling on the zoned parcel shall be for the primary or secondary residence of the owner of the parcel and shall not be rented or leased to another party. One (1) caretaker dwelling is permitted in the C-1 and I-1 zones as a conditional use, when the dwelling is located within the completed structure used for the principal use on the property or as a separate building meeting all requirements of this Code. Two additional parking spaces for the occupants of the caretaker dwelling shall be provided on the zoned lot containing the approved caretaker dwelling. County Health Department approval of the culinary water and sanitary sewer system is required before the building permit shall be approved for a caretaker dwelling.

02.0700 GENERAL PROVISIONS

02.0701 Intent

The intent of this section is to accumulate provisions applying to all land and buildings within the incorporated area of the Town into one section rather than to repeat them several times.

02.0702 Non-conforming Buildings and Uses

In view of the fact that no further development or change in use can be undertaken contrary to the provisions of this Ordinance, it is the intent of this Ordinance that non-conforming uses shall not be increased nor expanded except where a Health or Safety official, noting in his official capacity, requires such increase or expansion. Such expansion shall be no greater than that which is required to comply with the minimum requirements as set forth by the Health or Safety official. Nevertheless, a non-conforming building or structure or use of land may be continued to the same extent and character as that which legally existed on the effective day of

CHARLESTON TOWN

the applicable regulations. Repairs may also be made to a non-conforming building or to a building housing a non-conforming use.

Damaged Building May Be Restored

A non-conforming building or structure, or a building or structure occupied by a non-conforming use which is damaged or destroyed by fire, flood, wind, earthquake, or other calamity or act of nature or public enemy, may be restored, and the occupancy of use of such buildings, structure, or part thereof which legally existed at the time of such damage or destruction may be continued or resumed, provided that such restoration is started within a period of one year from the date of destruction and is diligently prosecuted to completion and provided that such restoration does not increase the floor space devoted to the non-conforming use over that which existed at the time the building became non-conforming.

Discontinuance or Abandonment

A non-conforming building or structure or portion thereof, or a lot occupied by a non-conforming use which is or hereafter becomes abandoned or is discontinued for a continuous period of one year or more, shall not thereafter be occupied except by a use which conforms to the use regulations of the zone in which it is located.

Change to a Conforming Use

A non-conforming use or building may be changed to a conforming use or building. Any non-conforming use or building which has been changed to a conforming use or building shall not thereafter be changed back to a non-conforming use.

Change to Another Non-Conforming Use Prohibited

A non-conforming use of a building or lot shall not be changed to another non-conforming use whatsoever. Changes in use shall be made only to a conforming use.

Reclassification of Territory

The provision pertaining to non-conforming uses of land and buildings shall also apply to land and buildings which hereafter become non-conforming due to an amendment in the Zoning Ordinance.

Permits Granted Prior to Passage of this Ordinance or Amendment Thereto

Notwithstanding the issuance of a permit therefor, no building which becomes non-conforming upon the passage of this Ordinance or which becomes non-conforming due to an amendment to this Ordinance shall be built unless construction has taken place thereon to the extent of at least \$1000.00 in replaceable value by the date on which this Ordinance or said amendment becomes effective. Replaceable value shall be construed to mean the expenditure necessary to duplicate the materials and labor at market prices.

Width Requirements

All primary structures erected in all zones must have a minimum width of twenty (20) feet at narrowest point of the structure.

02.0703 Non-conforming Lots of Record

Notwithstanding any other provision of this Ordinance, a one-family dwelling may be permitted on any lot of record in any zone in which dwellings are permitted, even though such lot fails to meet the area or width requirements for one-family dwellings within the zone, provided that where two or more contiguous lots of record having continuous frontage are owned by the same person at the time of the passage of the controlling ordinance, the land included in the lots shall be considered to be an undivided parcel and no portion of said parcel shall be used as a dwelling site or sold which does not meet the area and width requirements of

CHARLESTON TOWN

the zone in which the lot is located. Yard dimensions and other requirements not involving area or width shall conform to the regulations of the zone in which the lot is located except when granted a variance by the Land Use Appeal Authority.

02.0704 Annexations

All land hereafter annexed to the Town shall be classified in the RA-1 Agricultural Zone until the Planning Commission shall submit its recommendations for the zoning of the land to the Town Council and until the Town Council shall hold a public hearing thereon as required for amendments to the Zoning Ordinance and map.

02.0705 Amendments to Ordinance and Map

Zoning Change and Amendment Procedure to be as follows:

- 1) Written request for amendment of changes submitted to Planning Commission by:
 - A – Member of Planning Commission
 - B - Town Council Member
 - C - Town Person or another interested person
 - D- Town Staff
- 2) An application fee adopted by the Town Council will be required with the application unless the change or amendment is being made in behalf of the Town by an elected or appointed official or staff.
- 3) A public hearing on the change or amendment shall be scheduled with the Planning Commission; and noticed 10 days before in one of the three following methods:
 - A - Newspaper of general circulation in the area,
 - B - Posted on the Utah Public Notice Website
 - C - Posted on the Town’s official website, or posted in 3 public places
- 4) Written notice of said Public Hearing shall be sent to property owners of any property within 1,000 ft. of the purposed zone change, at least 10 days, prior to said Hearing.
- 5) The Planning Commission shall determine whether to recommend for or against said proposed zone change or amendment or to recommend an alternate amendment.
- 6) A public meeting on the zoning change shall be held with the Town Council to adopt or reject the zone change as proposed by the Planning Commission after making any revision the Town Council considers appropriate only after noticing the public meeting at least 24 hours prior to the Town Council Meeting. Said Notice shall:
 - A - Be posted on the Town’s website; or
 - B - In at least three public locations within Charleston Town.
- 7) If proposal is rejected then it shall be sent back to the Planning Commission.

02.0706 Notice To Neighbors

Notice shall be sent by US Mail as least three days before any meeting to all neighbors residing within 1000 feet for any Zone change, residential subdivision, multiple unit development or commercial or industrial development or subdivision.

02.0800 ESTABLISHMENT OF ZONES

02.0801 Zones Established

CHARLESTON TOWN

In order to carry out the purposes of this Ordinance, Charleston Town, Utah is hereby divided into zones as follows:

1. C-1 Commercial Zone
2. G-2 Grazing Zone
3. RA-1 Residential Agricultural Zone
4. RA-5 Residential Agricultural Zone
5. I Industrial Zone

02.0802 Official Zone Map

The location and boundaries of each of the zones are shown on the official Zone Map of Charleston Town, Utah, and said map is hereby declared to be an official record and a part of this Ordinance. (See Appendix A)

Whenever amendments or changes are made in zone boundaries, such amendments or changes shall be made on the Official Zone Map promptly. No amendment or change shall become effective until after it has been properly noted and attested to on the Official Zone Map.

No changes of any nature shall be made in the Official Zone Map except in conformity with the procedure set forth in this Ordinance. Any unauthorized change of whatever kind by any person or persons shall be considered a violation of this Ordinance and punishable as provided in this Ordinance.

Regardless of the existence of purported copies of the Official Zone Map which may from time to time be made or published, the Official Zone Map which shall be located in the office of the Town Clerk shall be the final authority in determining current zoning status.

02.0803 Boundaries of Zones

Where uncertainty exists with respect to the boundaries of various zones, the following rules shall apply:

1. Where the intended boundaries on the zone map are approximately street or alley + lines, said street or alleys shall be construed to be the zone boundaries.
2. Where the indicated boundaries are approximately lot lines, said lot lines shall be construed to be the zone boundaries, unless otherwise indicated.
3. Where land has not been subdivided into lots, the zone boundary shall be determined by the use of the scale of measurement shown on the map.
4. Where other uncertainty exists, the Land Use Appeal Authority shall interpret the map.

02.0900 REGULATIONS WITHIN ZONES

Within each of the zones, the use, location, height, and size of buildings and structures; the use of land and size of lots, yards, courts, and other open spaces, and the density of population are regulated as hereinafter set forth.

02.0904.00 C-1 COMMERCIAL ZONE

02.0904.01 Objectives and Characteristics of Zone

CHARLESTON TOWN

The C-1 Commercial Zone has been established for the primary purpose of providing a place where retail and service facilities can be established, where residents in the surrounding area can conveniently obtain daily household necessities and where the traveling public may also obtain goods and services. This zone is characterized by retail stores and service businesses.

It has been written that “Charleston is A Beautiful Corner of the Heber Valley.” In order to maintain the beauty, rural character and farming tradition of the Town of Charleston and to make the C-1 Commercial Zone property appealing to those that live in and pass through Charleston, the buildings constructed within the C-1 Commercial Zone shall be designed to reflect a “Ranch and Mountain Lodge” theme, as further described in Section 02.0904.04 E.

The C-1 Commercial Zone areas are primarily along Highway 189 and 113 running through the Town. The zone may be located adjacent to quality residential development and thus, the development within the zone must be beautified to create the highest degree of compatibility. The zone should always be located adjacent to collector and/or arterial streets. It is not the intent of this Chapter that the C-1 Commercial zone should become a catalyst for strip commercial development.

In order to accomplish the objectives and purposes of this Ordinance and the General Plan and to stabilize and protect essential characteristics of this zone, the following regulations shall apply in the C-1 Commercial Zone.

02.0904.02 Use Requirements

The following buildings, structures and uses of land shall be permitted in the C-1 Commercial Zone upon compliance with requirements as set forth in this Ordinance.

A. Permitted Principal Uses. The following principal uses are permitted in the C-1 Commercial Zone:

1. Research Services including laboratories, scientific, medical, and chemical, applied physics, mechanical, electronic, biological, genetic or other similar experimental research, product development or testing facilities, except those in which explosives or other highly dangerous materials are used.
2. Communications - including radio and television broadcasting (studios only), telephone company offices, recording and sound studios, and motion picture studios.
3. Data Processing Services.
4. Service Enterprises such as barber shops, reception centers, dance studios, dry cleaning and similar service enterprises.
5. Wholesale and retail stores and building and structures related thereto; provided that all merchandise, materials and equipment shall be stored within an enclosed building or within an outside enclosure surrounded by a sight-obscuring wood or vinyl fence or masonry wall at least six (6) feet in height. Storage exceptions granted for automobiles, trucks, and other vehicles in running order and seasonal items such as Christmas trees.
6. Office buildings and public utility buildings, except power plants.
7. Water wells, directional signs and name plates.
8. Cafes, service stations, food drive-ins;

CHARLESTON TOWN

9. Other uses similar to the foregoing uses which are ruled by the Planning Commission to be in harmony with the intent of this zone.

B. Permitted Secondary Uses. The following secondary activities which support or are accessory to the primary activities are permitted subject to the development and performance standards and conditions set forth herein. When located in the same building with another main use, secondary uses shall not occupy more than 30 percent of the total floor space.

1. Support and maintenance shops for the above uses.
2. Concessions and services which are provided for the convenience of the occupants of the buildings, provided they are located within a main building and there is no exterior evidence of such accessory uses such as signs or display windows.
3. Accessory building(s).
4. Printing, publishing and associated industries.
5. Indoor and screened storage activities and warehouse facilities are permitted only as part of a primary activity.
6. Daycare center in support of primary activity.
7. Off-street parking and parking structure incident to the above building uses.
8. Administrative offices for the permitted uses. These offices must be either in the same building or in a separate building on the same parcel as permitted use.
9. Residential uses, including mixed uses and caretaker dwellings.

C. Conditional Uses. The following uses and structures are permitted in the C-1 Commercial Zone only after a Conditional Use Permit has been issued, and subject to the terms and conditions thereof:

1. Marketing, telemarketing, and advertising services.
2. Auto, electronic and other repair establishments.
3. Convenience Stores, except that no convenience store shall be allowed within ¼ mile measured in a straight line from main entrance to main entrance of another convenience store.
4. Manufacturing, processing, and fabricating establishments, except those in which explosives or other highly dangerous materials are used or fabricated.
5. Fuel pumps and underground fuel storage
6. Pawn Shops noting that no pawn shop shall be allowed within one mile measured in a straight line from main entrance to main entrance of another of another Pawn Shop, Cigarette, Smoke or Vape shop.
7. Cigarette, Smoke or Vape Shops, noting that no Cigarette, Smoke or Vape shop shall be allowed within one mile measured in a straight line from main entrance to main entrance of another of another Cigarette, Smoke, Vape shop or Pawn Shop.
8. Off Premises Beer Retailer. Applicable provisions of the Utah alcoholic beverage control act pertaining to off premises beer retailer licenses as set forth at Utah Code Annotated section 32B-7-101 et seq., as currently adopted and as hereinafter amended are adopted. An off-Premises Beer Retailer License from Charleston Town may be issued to an eligible person for a qualifying location, with the following exceptions:

CHARLESTON TOWN

- a. Location Restrictions: A Charleston off premises beer retailer license will not be issued to any person where the premises would be located within three hundred feet (300') of a community location, such as a public or private school, church, public library, public playground or park as measured from the nearest entrance of the outlet by following the shortest route of either ordinary pedestrian traffic, or where applicable, vehicular travel along public thoroughfares, whichever is the closer, to the property boundary of a public or private school, church, public library, public playground or park. The location of a Charleston Town off premises beer retailer licensee may not be established within one hundred feet (100') of any community location, measured in a straight line from the nearest entrance of the proposed outlet to the nearest property boundary of the public or private school, church, public library, public playground or park.
 - b. Hours: A Charleston Town off premises beer retailer licensee may only sell beer between the hours of seven o'clock (7:00) A.M. and one o'clock (1:00) A.M.
 9. Drive-up Windows situated so that they do not create a traffic flow problem on the lot they serve, neighboring lots, or public streets.
 10. Car washes situated so that they do not:
 - a. Create ice build-up or traffic flow problems on the lot they serve, neighboring lots, or public streets.
 - b. Emit nuisance noise issues to neighboring lots.
 - c. Time of operation restrictions may be imposed as part of the conditional use approval.
 11. Bed and Breakfast Establishments.
 12. Self-Storage facilities under the following conditions:
 - a. Maximum of 11.5 total acres of Self-Storage Facilities allowed in the C-1 Zone;
 - b. Proposed self-storage facility is at least 2 acres but not more than 6 acres;
 - c. No storage is allowed outside of enclosed buildings;
 - d. Perimeter landscape requirements and site obscuring fencing for a self-storage facility shall be determined with the conditional use permit application with the Planning Commission and recommended to the Town Council for final approval;
 - e. Time of operation restrictions may be imposed as part of the conditional use approval; and
 - f. Other reasonable conditions as deemed necessary.
 13. Other similar and compatible uses. Other similar uses not specifically listed above may be approved by the Town Council, with the issuance of a conditional use permit, upon findings that the proposed use most closely fits within one of the listed categories, and that any expected impacts will be no greater than that of other uses listed.
 14. Violations of reasonable conditions imposed may be cause, after a duly noticed hearing, for the Town Council to revoke any conditional use permit.
- D. Prohibited Uses.** The permitted uses enumerated above shall not be construed to include, either as a main or accessory use, any of the following uses. This list of prohibited uses is not exhaustive, but is intended to be illustrative of the type of uses which are not allowed:
1. Terminals, including truck or bus terminals, and other distribution facilities.
 2. Sand, gravel and other extraction mining.
 3. Junk or salvage yards.

CHARLESTON TOWN

4. Liquor stores.
5. Above ground fuel storage
6. Sexually Oriented Businesses—See Section 02.1000 Sexually Oriented Businesses
7. Hotels
8. Motels
9. Multi-level Parking Structures
10. Laundromats
11. Vacation or Recreation Vehicle Courts
12. Explosive, flammable or highly combustible material, storage, sales, processing or production.
13. Asphalt and concrete mixing and similar operations.
14. Uses which are determined to violate any activity prohibited in the Town's Nuisance abatement ordinance.
15. Other similar, non-compatible uses not specifically listed above may be prohibited by the Town Board, upon findings that the proposed use is similar in negative impacts to the surrounding area as to those uses listed above.

02.0904.03 Area, Width, Location, Height Requirements:

- A. There shall be no minimum area or width requirements for lots in the C-1 zone, except as may be otherwise required by another section of this ordinance
- B. The setback requirements for this zone shall be as follows:
 1. Front Setback. All buildings and structures shall be set back at least thirty (30) feet from any street right-of-way or sixty-five (65) feet from the center line of the road, whichever is greater. Fuel pump islands and canopies shall have a setback of at least fifty (50) feet from any highway right-of-way and as otherwise required in section 02.0600.20 of this ordinance.
 2. Side Setback, Interior Lots. No building shall be located closer than ten (10) feet to side property line
 3. Side Setback, Corner Lots. Corner lots shall be treated as if they have two (2) front setbacks.
 4. Rear Setback, Interior and Corner Lots. No building shall be located closer than twenty (20) feet to any rear property line or thirty (30) feet to any road or highway right of way line,
 5. Setbacks from Residential Zones or uses. All buildings shall set back at least thirty (30) feet from any residential zone or use and may be required to provide a wall and/or landscape buffer, as approved by the Planning Commission, to screen the commercial use from such residential zone or use.
- C. No building shall be higher than thirty-five (35) feet from the natural grade, except as otherwise allowed in this ordinance.

02.0904.04 Special Provisions

- A. **Landscaping.** The following landscaping requirements and standards shall apply in the C-1 Commercial zone and shall be in addition to requirements of Section 02.0600 Supplementary Requirements and Procedures Within All Zones:
 1. The area of front, side, and rear yards along an adjacent property line and extending away from the property line a distance prescribed in the requirements of this

CHARLESTON TOWN

- subsection shall be landscaped with grass, trees, other approved live plant material and other approved landscaping materials.
2. The required yard landscape area for a yard adjacent to a residential or agricultural zone shall be not less than thirty feet (30)'.
 3. The required yard landscape area for a yard adjacent to a public right of way shall be twenty feet (20)'.
 4. All areas of lots or parcels in commercial zones not approved for parking, buildings, or other hard surfacing shall be landscaped and properly maintained with grass, deciduous and evergreen trees, and other plant material in conjunction with a landscape plan for the development that has been designed and prepared by a landscape architect and approved by the Planning Commission.
 5. A minimum of one tree per five hundred (500) square feet of mandatory landscaping is required in the C-1 Commercial Zone. A minimum of thirty percent (30%) of these trees shall be planted in evergreens. Each at least seven feet (7') tall. Deciduous trees shall be of a minimum two-inch (2") caliper. Deciduous and evergreen trees required in this section need not be equally spaced but shall be dispersed throughout the required yard areas on the site.
 6. All collector streets, right of way, and other public and private park strips in commercial zones shall be improved and maintained by the adjoining owners according to specifications adopted by the Town unless otherwise allowed with development approval.
 7. Trees shall not be topped and required landscape areas shall not be redesigned or removed without town approval. Property owners shall replace any dead plant material in accordance with the requirements of this chapter and the conditions of site plan or plat approval.
 8. The following landscaping requirements shall apply to parking areas:
 - a. Curbed planters with two inch (2") or larger caliper shade trees and grass, shrubs or ground cover shall be installed at the ends of parking rows. Planters shall be at least five feet (5') wide.
 - b. All landscaped areas adjacent to parking areas shall be curbed.
 9. Developments that are contiguous to canals, streams or drainage areas shall make reasonable efforts to include banks and rights of way in the landscaping of the project and the trails system. Any areas so included and perpetually preserved may be counted toward required yard space for the development. If approved by the city engineer, waterways which traverse developments may be left open if properly landscaped and maintained by the adjacent owners. Waterways may not be altered without written approval of any entity or agency having jurisdiction over said waterways.
 10. All required landscaping shall be installed (or escrowed due to season) prior to a Certificate of Occupancy being granted.
 11. All landscaped areas, including adjoining public rights of way, shall be properly irrigated and maintained by the owners.
 12. Berms may be required for screening purposes and shall be constructed in accordance with Section 02.0600.43: Landscaping and Other Berms.
 13. Fences shall be constructed from decorative iron, wood, vinyl, or other materials, as approved by the Planning Commission.

CHARLESTON TOWN

- B. Parking.** All off-street parking spaces shall be hard-surface. Parking spaces drive aisles shall comply with Section 02.0600.29 Off-Street Parking, Access and Loading, contained within this Ordinance.
- C. Lighting.** All site lighting within the C-1 Commercial zone shall comply with Section 02.0600.27 Lighting, as contained within this Ordinance
- D. Garbage, recycling and other similar waste containers.** Waste containers shall be required for all commercial uses for the storage of garbage, recycling or other similar waste and will require a regularly scheduled pickup. All containers for garbage, recycling and other similar waste shall be screened from view by a six foot, gated, masonry wall that matches the building it serves, as reviewed and approved by the Planning Commission.
- E. Architectural Design**
1. Ranch and Mountain Lodge Architecture Requirement:
 - a. All buildings shall be designed to a “Ranch and Mountain Lodge” theme.
 - b. The Ranch and Mountain Lodge theme is generally described as nostalgic architecture that reminds residents and visitors of the heritage, beauty, and rural living that the Charleston community has to offer.
 - c. The Ranch and Mountain Lodge theme is meant to allow design creativity yet draws its inspiration from the more attractive structures of the region.
 2. Ranch and Mountain Lodge Design Elements:
 - a. Exterior Walls:
 - i. Logs, timbers, and natural or approved colors of sawn, re-sawn wood siding or fiber cement siding products are encouraged.
 - ii. Metal siding, Masonite siding, T-111, hardboard siding, or other non-cement synthetic simulated wood siding products are generally not allowed, but may be approved by the Planning Commission, depending on the individual site location of a building or placement or its placement on specific areas of a property so long as the visual impression on the quality of architectural style expected in the Ranch and Mountain Lodge design is maintained.
 - iii. Stucco shall be allowed in approved colors, with no more coverage than twenty-five (25) percent of the front walls forty (40) percent of the side walls and sixty (60) percent of the rear walls of any building. Any building side that faces a public street at less than a sixty (60) degree angle measured from the general direction of the street line shall be treated as a building front.
 - b. Roofing Pitch and Materials: Roofs shall be designed on all structures to a pitch in harmony with the Ranch and Mountain Lodge style the building is designed to reflect, and as approved by the Planning Commission. Roofing materials allowed by the Building Code will be acceptable in colors and styles that match and that are in harmony with the rest of the architectural style of the building, as approved by the Planning Commission.
 - c. Brick, rock and mortar pattern as approved by the Planning Commission.
 - i. No plain, concrete or cinder block is allowed.
 - ii. No large areas of foundations or raw concrete retaining walls are to be exposed and must be covered by the exterior wall material, painted in an approved color or screened.
 - d. Any fireplace flues should be enclosed, topped with a chimney cap, and should show a minimum of exposed metal or clay flues.

CHARLESTON TOWN

- e. All vents roof mounted mechanical equipment shall be screened in a manner in which to make it blend with the building, as seen from the street view(s).
- f. Copulas and weathervanes shall be allowed to extend above the thirty-five (35) foot height limit up to eight (8) feet and shall be in harmony with the architecture of the primary structure.
- g. Window casings shall be wood or approved simulated wood look.
 - i. Approved finishes are natural, stained, painted, and metal or vinyl clad.
 - ii. Exterior window style shall relate to other building materials in the structure.
 - iii. Aluminum windows are not allowed.
 - iv. Reflective glass in any window is not allowed.
- h. Doors and Entryways:
 - i. The primary entrance doorway shall establish interest and character. Doors and entryways should be constructed from solid wood materials, whenever possible.
 - ii. Secondary man and overhead doors may be metal with a faux wood finish, subject to Planning Commission approval.
 - iii. Accessory buildings and additions to primary structure(s) must be approved by the Planning Commission and must appear as though they were designed in harmony with the primary structure(s) and not added as an afterthought. Therefore, design and materials must be compatible with the architecture of the primary structure(s).

F. Business Licenses: All businesses shall obtain and keep a current business license.

- 1. The Town Clerk has the right to refuse to issue or to revoke an existing business license for any business who is known to be violating a criminal, civil, local, state, or federal ordinance, statute, rule or law.

02.0904.05 Site Plan and Platting Requirements Site plans shall be processed under the requirements for Subdivision Plats as outlined in Title 10 Charleston Town Subdivision Ordinance. If a subdivision Plat is requested, it may be run simultaneously with the Site Plan, at the applicant's own risk. Notwithstanding the foregoing, any request for zoning, deviations from zoning or development standards requiring a development agreement or other legislative action, may not be combined or considered with a subdivision application.

02.0908.00 G-2 Grazing Zone

02.0908.01 Objectives and Characteristics of Zone

The G-2 Grazing Zone has been established for the primary purpose of:

- a) Encouraging the proper development and conservation of the Town's natural resources.
- b) Providing a place where certain uses can be located which are detrimental to other uses when situated in close proximity to such other uses.
- c) Avoiding unnecessary expenditures of public funds due to excessive scattering of urban uses.

This zone is characterized by large tracts of mountainous and open-range land. In order to accomplish the objectives and purposes of this Ordinance and to stabilize and protect the

CHARLESTON TOWN

essential characteristics of this zone, the following regulations shall apply in the G-2 Grazing Zone.

02.0908.02 Use Requirements

The following buildings, structures, and uses of land shall be permitted in the G-2 Grazing Zone upon compliance with requirements as set forth in this Ordinance:

- a) The raising, care, and keeping of animals and fowl.
- b) Barns, corrals, pens, coops, and feed storage buildings for the care of and keeping of animals and fowls.
- c) Fences.
- d) Other uses ruled by the Land Use Appeal Authority to be similar to uses specifically permitted in the zone and which will harmonize with the objectives and characteristics of the G-2 Grazing Zone.

02.0908.03 Area. Width. Location. Height, and Size of Buildings Requirements

There shall be no area requirements

02.0908.04 See also Supplementary Requirements and Procedures Applicable Within

ALL Zones: Unless superseded by specific requirements in this section, the applicable requirements and procedures within Section 02.0600 shall apply to the Grazing (G) zone unless specifically waived by the Town Council in the site plan or conditional use approval process.

02.0909.00 RA-5 RESIDENTIAL – AGRICULTURAL ZONE

02.0909.01 Objectives and Characteristics of the Zone

The RA-5 Residential – Agricultural Zone is established to provide areas within the corporate area of Charleston Town where residential uses may be harmoniously integrated with incidental agricultural pursuits. This zone is intended to allow the keeping of farm animals and fowl in conjunction with single-family dwelling units to an extent consistent with said development, and in proportion to the amount of land area provided for this purpose. It is intended, at the same time, to retain land in parcels large enough to provide efficient and attractive development as urban uses extend in an orderly manner into these areas.

02.0909.02 Use Requirements

The following buildings, structures, and uses of land shall be permitted in the RA-5 Residential – Agricultural Zone upon compliance with requirements as set forth in this Ordinance:

- a. Agricultural.
- b. Single-family dwellings and buildings accessory thereto.
- c. Home occupations and premise occupations, subject to conditions set forth in Section 02.0628 of this Ordinance.
- d. Schools, churches, public parks and playgrounds, arboretums, public buildings.
- e. The raising, care and keeping of animals and fowl for family use and consumption provided that no animal shall be kept on lots containing less than one (1) acre of land.
- f. Farm machinery and farm products, storage sheds.
- g. Barns, corrals, pens coops, sheds and feed storage buildings for the keeping of animals and fowl, storage of farm products, and small animal hospitals without outside runs.

CHARLESTON TOWN

- h. Rest homes are subject to approval by the appropriate State Agencies.
- i. Day-care nurseries which have been approved by the appropriate State Agencies.
- j. Fences, walls, and hedges
- k. Water reservoirs, ponds, dams, water pumping plants and pipelines, flood control structures, public utility buildings (except power plants, water wells, utility transmission lines and substations, sewage treatment plants subject to review and approval by the State Division of Health.
- l. Accessory signs not exceeding fifteen (15) square feet in area pertaining to the sale of property or produce raised on the premises, also name plates not exceeding 226 square inches in area.
- m. Temporary buildings and yards for the storage of construction materials and equipment incidental and necessary to construction of uses otherwise permitted in the zone
- n. Cemeteries, public and private, subject to the laws of the State of Utah when approved by the Land Use Appeal Authority.
- o. Premise Occupations with a permit issued under Section 02.1150 is this Title.
- p. Other uses ruled by the Land Use Appeal Authority to be similar to the uses specifically permitted in the zone and which will harmonize with the objectives and characteristics of the RA-5 Residential – Agricultural Zone.

02.0909.03 Area Requirements

Except within an approved Cluster and Farm Subdivision, as defined in Section 02.0909.08, the minimum building site area shall be one recorded lot or parcel of land not less than five (5) acres in area for each one-family dwelling and not less than one and one-half acres for day-care nursery, or rest home.

02.0909.04 Width Requirements

The minimum width requirements for any building site shall be 250 ft.

02.0909.05 Location Requirements

The location requirements shall be as follows:

Front Setback

All buildings and structures shall be set back at least thirty (30) feet from the front lot line, or fifty-five feet (55) from the centerline of the road, whichever is greater.

Side Setback

All dwellings shall be set back from the side property line a distance of at least ten (10) feet, and the total distance of the two side setbacks shall be at least twenty-four (24) feet. The minimum side setback for accessory buildings shall be the same as for main buildings, except that a three (3) foot side setback shall be required for accessory buildings which are located more than one hundred (100) feet from the front lot line and at least twelve (12) feet in the rear of any dwelling. On corner lots, the side setback from any street shall not be less than thirty (30) feet for both main and accessory buildings.

Rear Setback

For interior lots, all dwellings and other main buildings shall be set back from the rear property line a distance of at least thirty (30) feet. Accessory buildings or interior lots shall be set back not less than ten (10) feet from the rear property line, except that no rear setback shall be required for accessory buildings having fire-resistive walls for two (2) hours or more. For corner lots, all dwellings and other main buildings shall be setback

CHARLESTON TOWN

from the rear property line a distance of at least thirty (30) feet, except that for dwellings having an attached garage or carport, the setback shall not be less than twenty (20) feet. Accessory buildings on corner lots shall be setback from the rear property line a distance of not less than three (3) feet.

02.0909.06 Size of Dwellings

The ground floor area of any single-family dwelling shall be not less than one thousand two hundred (1,200) square feet.

02.0909.07 Special Provisions

For the purpose of determining front, side, and rear setback requirements, any separate building situated within twelve (12) feet from a dwelling, or other main building, shall be considered as a part of the main building and not as an accessory building.

02.0909.08 - Supplementary Requirements and Procedures Applicable Within All Zones.

Unless superseded by specific requirements in this section, the applicable requirements and procedures within Section 02.0600 shall apply to Residential Agricultural Five Acre Zone (RA-5) unless specifically waived by the Town Board in the site plan or conditional use approval process.

02.0910.00 RA-1 RESIDENTIAL - AGRICULTURAL ZONE

02.0910.01 Objectives and Characteristics of the Zone

The RA-1 Residential-Agricultural Zone is established to provide areas within the corporate area of Charleston Town where residential uses may be harmoniously integrated with incidental agricultural pursuits. This zone is intended to allow the keeping of farm animals and fowl in conjunction with single-family dwelling units to an extent consistent with said development, and in proportion to the amount of land area provided for this purpose. It is intended, at the same time, to retain land in parcels large enough to provide efficient and attractive development as urban uses extend in an orderly manner into these areas.

02.0910.02 Use Requirements

The following buildings, structures, and uses of land shall be permitted in the RA-1 Residential-Agricultural Zone upon compliance with requirements as set forth in this Ordinance.

- a) Agriculture.
 - b) One- and two-family dwellings and buildings accessory thereto.
 - c) Home occupations are subject to conditions set forth in Section 02.0628 of this Ordinance.
 - d) Schools, churches, public parks and playgrounds, arboretums, public buildings.
 - e) The raising, care and keeping of animals and fowl for family use and consumption, provided that no animal shall be kept on lots containing less than one (1) acre of land.
 - f) Farm machinery and farm products, storage sheds.
 - g) Barns, corrals, pens, coops, sheds and feed storage buildings for the keeping of animals and fowl, storage of farm products, and small animal hospitals without outside runs.
 - h) Rest homes are subject to approval by the appropriate State Agencies.
 - i) Day-care nurseries which have been approved by the appropriate State Agencies
- Fences, walls, and hedges

CHARLESTON TOWN

- j) Water reservoirs, ponds, dams, water pumping plants and pipelines, flood control structures, public utility buildings (except power plants), water wells, utility transmission lines and substations, sewage treatment plants subject to review and approval by the State Division of Health
- k) Accessory signs not exceeding fifteen (15) square feet in area pertaining to the sale of property or produce raised on the premises, also name plates not exceeding 226 square inches in area.
- l) Temporary buildings and yards for the storage of construction materials and equipment incidental and necessary to construction of uses otherwise permitted in the _____ zone
- m) Cemeteries, public and private, subject to the laws of the State of Utah when approved by the Land Use Appeal Authority.
- n) Other uses ruled by the Land Use Appeal Authority to be similar to uses specifically permitted in the zone and which will harmonize with the objectives and characteristics of the RA-1 Residential-Agricultural Zone.

02.0910.03 Area Requirements

Except within an approved Cluster and Farm Subdivision, as defined in Section 02.0910.08, the minimum building site area shall be one recorded lot or parcel of land not less than one acre in area for each one-family dwelling and not less than one and one-half acres for each two-family dwelling, day-care nursery, or rest home.

02.0910.04 Width Requirements

Except within an approved Cluster and Farm Subdivision, as defined in Section 02.0910.08, the minimum width requirements for any building site shall be 200 feet.

02.0910.05 Location Requirements

Except within an approved Cluster and Farm Subdivision, as defined in Section 02.0910.08, the location requirements shall be as follows:

Front Setback

All buildings and structures shall be set back at least thirty (30) feet from the front lot line, or fifty-five feet (55) from the centerline of the road, whichever is greater.

Side Setback

All dwellings shall be set back from the side property line a distance of at least ten (10) feet, and the total distance of the two side setbacks shall be at least twenty-four (24) feet. The minimum side setback for accessory buildings shall be the same as for main buildings, except that a three (3) foot side setback shall be required for accessory buildings which are located more than one hundred (100) feet from the front lot line and at least twelve (12) feet in the rear of any dwelling. On corner lots, the side setback from any street shall not be less than thirty (30) feet for both main and accessory buildings.

Rear Setback

For interior lots, all dwellings and other main buildings shall be set back from the rear property line a distance of at least thirty (30) feet. Accessory buildings on interior lots shall be set back not less than ten (10) feet from the rear property line, except that no rear setback shall be required for accessory buildings having fire-resistive walls of two (2) hours or more. For corner lots, all dwellings and other main buildings shall be setback from the rear property line a distance of at least thirty (30) feet, except that for dwellings having an attached garage or carport, the setback shall not be less than twenty (20) feet.

CHARLESTON TOWN

Accessory buildings on corner lots shall be setback from the rear property line a distance of not less than three (3) feet.

02.0910.06 Size of Dwellings

The ground floor area of any one (1) and two (2) family dwelling shall be not less than one thousand (1,000) square feet.

2.0910.07 Special Provisions

For the purpose of determining front, side, and rear setback requirements, any separate building situated within twelve (12) feet from a dwelling, or other main building, shall be considered as a part of the main building and not as an accessory building.

02.0910.08 Cluster And Farm Subdivisions

A. Purpose and Intent:

The cluster and farm subdivision option is provided by the town to encourage creativity in subdivision design, to encourage the achievement of the goals and policies of the town general plan and to allow for the protection of the natural features and the provision of features and amenities for the subdivision site and the town. Full compliance with all the provisions of this title and all other applicable local, state and federal requirements is required.

A. Use Regulations:

The cluster and farm subdivision option may be permitted, or required, in the Agricultural-residential (A-1) zoning district by the town board, following receipt of a planning commission recommendation. An application for a cluster or farm subdivision shall be considered concurrently with an application for subdivision approval. All use and subdivision application requirements of the zoning district in which the cluster or farm subdivision is located shall apply. The Town Council may reject an application for a cluster and farm subdivision if it finds the parcel to be too small or of an irregular shape such that the provisions of this title cannot be effectively adhered to.

C. Development Standards:

Minimum Lot Area:

The minimum lot area may be reduced below the minimum lot area required by the zoning district requirements in which the cluster or farm subdivision is located, as recommended by the Planning Commission, and as approved by the Town Council. However, no lot shall be less than one-third (1/3) acre, recognizing the need to provide adequate culinary water and sanitary sewer services and the gross density of the subdivision shall not exceed one lot per acre in

Minimum Lot Width And Minimum Yard Requirements:

The minimum lot width, side yard, front yard and rear yard requirements of the zoning district in which the cluster or farm subdivision is located, may be reduced as recommended by the Planning Commission, and as approved by the Town Council. However, no required side yard shall be less than twelve feet (12'), no required front or rear yard shall be less than thirty feet (30') and no corner side yard shall be less than twenty feet (20').

Use and Height Requirements:

CHARLESTON TOWN

All cluster and farm subdivisions are required to comply with the use and height requirements of the zoning district in which they are located.

Home Sizes:

The Planning Commission may recommend and the Town Council may require home sizes within a cluster and farm subdivision to be in scale with homes on surrounding plats. Such requirements and the affected lots shall be noted on the subdivision plat before recordation.

Restrictive Covenants and Title Report required:

The applicant shall submit, with the final plat, a current title report and a copy of the covenants, conditions and restriction documents (CC&R's) in compliance with this code to be reviewed by the city attorney. A current title report is considered to be one which correctly discloses all recorded matters of title regarding the property, and which is prepared and dated not more than thirty (30) days before the proposed recordation of the final map. The applicant shall submit the improvement guarantee and any other documents and information required by the city attorney. The following language shall be included in the appropriate section of all declarations of covenants, conditions and restrictions (or similar documents) for cluster and farm subdivisions approved by the Town of Charleston. Charleston Town shall have the right, but not the duty, to require, and if necessary, perform, at the Association's expense, landscaping, maintenance, and snow removal within the common areas if the Association fails adequately to perform such. In the event Charleston Town exercises this right, the Town shall be entitled to recover any associated costs and attorney fees. In addition, the owners within this project, by virtue of purchasing a dwelling unit within this development, give Charleston Town the right, but not the duty to form, under State statutes, a Special Service District (SSD) for the purpose of ongoing maintenance or a Special Improvement District (SID) for the purpose of making needed improvements within the project. The Town may take this action when either asked to take over improvements or maintenance tasks by the Homeowners Association, or by an owner. The Town Council may also take one or both of these actions when it determines the need based on a historical pattern of a lack of care and maintenance. The Governing Body of any such district formed, as stated in this paragraph, shall consist of the Charleston Town Mayor, Town Council and the Homeowners Association President of the project. This section shall not be amended or deleted without the approval of the Town of Charleston. Variations of this paragraph may be approved by the city attorney when individual circumstances dictate.

Required Services:

The proposed cluster or farm subdivision must comply with the requirements for culinary water, sewage and storm drainage as required for preliminary subdivision plat applications, final plat applications, minor subdivision applications or property split subdivision applications, as applicable.

On Site & Off Site Improvements:

The proposed cluster or farm subdivision may be required to provide on-site and off-site improvements, facilities and amenities, as required for final plat applications, minor subdivision applications, and property split subdivision applications, as applicable.

Open Space:

At least forty (40) percent of the gross land area contained within the development shall be preserved for dedicated open space. Open space may be segregated or be part of the platted lots. If the open space is part of the platted lots, the plat shall designate "No build areas" on the plat to ensure the open space remains in perpetuity. The Town Council may

CHARLESTON TOWN

require that segregated land be made a part of the lot design when it finds that the open space will become a burden on either the town or a homeowner's association.

Landscaping of Open Space:

A landscaping and maintenance plan for all areas receiving open space credit shall be submitted with the preliminary and final plans. Before recordation of the plat, a cash bond for the installation of the landscaping and maintenance for a period of five years shall be placed in an escrow account with the town mayor's signature being required for draws. The bond shall be for 125% of the applicant's engineer's estimate of the above costs, as approved by the town engineer.

Pedestrian Circulation:

Pedestrian circulation shall be determined on a case-by-case basis. All developments shall comply with the town's trail plan and may be required to connect with the Wasatch County Trail Plan if applicable. The applicant shall propose sidewalks and/or trails. The Planning Commission shall make a recommendation on the proposed sidewalks and/or trails to the Town Council to approve as is or with modifications.

D. Farm Area and Open Space Provision and Maintenance:

All areas to be preserved for farm use and/or open space area resulting from a cluster or farm subdivision approval shall be preserved in perpetuity. These areas shall only be used, and shall be maintained in accordance with the conditions of the cluster or farm subdivision approval, as recommended by the Planning Commission, and approved by the Town Council. Such area(s) shall be noted on the subdivision plat as an agricultural or open space area with future residential and commercial development prohibited. Agricultural buildings and businesses may be allowed in the Open Space area as a conditional use or premise occupation approvals under Section 02.0627 of this Title.

E. Cluster or Farm Subdivision Applications:

An application for a cluster subdivision approval or a farm subdivision approval shall be submitted to the town planner in accordance with the requirements for a preliminary subdivision plat application, a minor subdivision application, or property split subdivision application as applicable, and as required by this title.

02.0910.09 - Supplementary Requirements and Procedures Applicable Within All Zones.

Unless superseded by specific requirements in this section, the applicable requirements and procedures within Section 02.0600 shall apply to Residential Agricultural One Acre Zone (RA-1) unless specifically waived by the Town Council in the site plan or conditional use approval process.

02.0911.00 INDUSTRIAL ZONE

02.0911.01 Objectives & Characteristics of the Industrial (I) Zone

This zone district is established for the purposes of providing locations for those industrial land uses that are consistent with and supportive of the goals of the Charleston General Plan. This zone district is intended to encourage industrial development near incorporated municipalities, where adequate services are generally available. However, it also is intended to permit an appropriate diversity of economic activity at other appropriate locations to support the needs of Charleston residents when appropriate services can be made available and the use is

CHARLESTON TOWN

compatible with its surroundings. Industrial uses are reviewed through the conditional use review process.

02.0911.02 Existing Legal Non-conforming Industrial Uses:

Existing legal nonconforming industrial uses not located within an industrial zone district may continue and may be enlarged and/or expanded if approved by the Town Council under the industrial use criteria listed in subsection 02.0911.03 of this section.

02.0911.03 Industrial Zone and Use Criteria:

The Town Council shall approve the site plan for all new and expanded industrial uses. New industrial uses shall not be established nor shall existing industrial uses be expanded within the industrial zone unless the use complies with all of the following criteria:

1. There is adequate off-street parking and circulation areas and direct access to a major roadway from the property where heavy equipment or truck traffic will not travel through established residential neighborhoods.
2. Public services are readily available to the property and can be provided at adequate levels to serve the demands of the industrial use without negatively impacting the level of service to adjoining uses to existing industrial uses.
3. The industrial use is compatible and is consistent with or supports other nearby uses and/or property conditions.
4. The property does not contain sensitive lands that cannot be mitigated if negatively impacted by the commercial/industrial use.
5. A final site plan, design guidelines and operational management plan will be required as part of any site plan, conditional use, rezoning or expansion of an industrial use to fully address potential impacts to neighboring uses or the community at large.

02.0911.04 Floor Area and Lot Coverage

Floor area and lot coverage requirements in the industrial zones shall be dictated by off street parking, adequate circulation and other site design requirements and development standards. The maximum floor area or lot coverage shall not exceed sixty percent (60%) of the lot.

02.0911.05 Lot Width

There shall be no requirement for lot width, provided all off-street parking and circulation requirements can be satisfied.

02.0911.06 Setback Requirements

Minimum setbacks for industrial uses shall be determined through the site plan approval or conditional use review process.

Wetlands and Streams:

The minimum setback from wetlands shall be forty feet (40'). The minimum setback from any other naturally occurring year-round stream, lake, pond or reservoir shall be one hundred feet (100') from the ordinary high-water mark.

02.0911.07 Parking

Parking shall generally be located at the side or rear of industrial buildings with only limited parking allowed at the front of the building between the roadway of the building.

CHARLESTON TOWN

02.0911.08 Building Height

Maximum building height shall be thirty-five feet (35') unless additional building height is required for the industrial use and is approved by the Planning Commission and is determined to be compatible with adjacent buildings and uses.

02.0911.09 Special Requirements

Special landscape screening and other buffer requirements, to the extent practical and reasonable, may be required to minimize the impact on adjacent uses. Special screening and buffer requirements shall be determined through the site plan or conditional use review processes.

02.0911.10 Permitted Uses

The following uses shall be permitted within the Industrial (I) Zone.

1. Commercial establishments, not to exceed 5,000 square feet.
2. Nursery/Greenhouse.
3. Open Space, Agriculture/Grazing and Meadowlands.
4. Open Recreation Uses.
5. Telecommunications facilities – stealth.
6. Underground utility uses, including transmission lines for natural gas, water, sewer, telephone, power, etc.
7. Utility towers and associated transmission and distribution lines 45 feet in height or less.
8. Utility structures and related facilities.
9. Warehousing and commercial storage.

02.0911.11 Conditional Uses

After approval of the Town Council, the following uses shall be conditionally permitted within the Industrial (I) zone exclusively:

1. Cemetery
2. Commercial establishments, exceeding 5,000 square feet.
3. Convenience stores, including the sale of motor fuels and car washes.
4. Expansion of lawful nonconforming, commercial and industrial uses and buildings.
5. Industrial establishments, uses and operations including storage, manufacturing and processing.
6. Institutional uses including fire stations and public or quasi-public buildings.
7. Kennels for commercial or private use for 4 or more dogs or cats.
8. Rock quarries, gravel pits, and associated surface, mining uses, including, but not limited to, filtering, sifting, and processing of soil.
9. Telecommunications facilities – collocation.
10. Underground transmission lines exceeding 12 inches in diameter (i.e. gas, oil, water, etc.).
11. Utility towers and associated transmission and distribution lines greater than 45 feet in height.
12. Wind power generation facilities.

CHARLESTON TOWN

No legally nonconforming use shall be expanded or changed from the original conditional use approval unless and until the Town Council amends said conditional use approval.

02.0911.12 Supplementary Requirements and Procedures Applicable Within All Zones:

Unless superseded by specific requirements in this section, the applicable requirements and procedures within Section 02.0600 shall apply to the Industrial (I) zone unless specifically waived by the Town Council in the site plan or conditional use approval process.

02.1000 SEXUALLY ORIENTED BUSINESSES

Charleston Town hereby adopts County Ordinance 16.31.01-04 as section 02.1000 of the Charleston Zoning Ordinance.

02.1100 ADMINISTRATION AND ENFORCEMENT

02.1101 Building Permits Required, Application

No person, firm, or corporation shall commence to construct, alter or move a building or structure, or to make a change in use of any land within the territory shown on the zone map which has been adopted as a part of this Ordinance without first submitting an application and obtaining a permit from the Zoning Administrator or other authorized officer, provided, however, that permits for the moving of structures shall be granted only after complying with the requirements as Set forth in the Conditional Use Section. A permit shall also be required for the moving and/or improvement of moved-in homes, demountable homes, manufactured homes, and similar movable structures.

02.1102 Plans Required

All applications for building permits shall be accompanied by plans which have been drawn to scale showing the actual dimensions of the lot to be built upon, the size and location of existing buildings, and as required, the location and layout of off-street parking and a planting plan showing how the premises will be landscaped. A careful record of said application and plans shall be kept in the office of the Building Inspector for a period of time specified by the State GRAMA Law.

02.1103 Permits to Comply with Ordinance

From the time of the effective date of this Ordinance, permits shall not be granted for the construction or alteration of any building or structure or for the moving of a building or structure onto a lot or for the change in use of any land, building, or structure, if such construction, alteration, moving, or change in use would be a violation of any of the provisions of this Ordinance, nor shall any sewer or water service line or electric utilities be installed to serve the premises if such use would be in violation of this Ordinance.

02.1104 License to Comply with Ordinance

No license shall be issued by an official or employee vested with the duty and authority to issue licenses which would not be in conformity with the provisions of this Ordinance. Any license so issued shall be null and void.

02.1105 Construction and Use to Comply with Application

CHARLESTON TOWN

A building permit or Certificate of Zoning Compliance issued on the basis of plans and specifications approved by the Zoning Administrator authorize only the use, arrangement and construction set forth in such approved plans and application, and no other use, arrangement, or construction. Use, arrangement, or construction different from that authorized shall be deemed to be a violation of this Ordinance.

02.1106 Certificate of Zoning Compliance Required

It shall be unlawful to use or occupy or permit the use or occupancy of any building or premise, or to change the occupancy of any building or premise until a Certificate of Zoning Compliance shall have been issued by the Zoning Administrator, stating that the proposed use of the building or land conforms to the requirements of this Ordinance. No non-conforming structure or use shall be changed or extended until a Certificate of Zoning Compliance shall have been issued by the Zoning Administrator. The Certificate of Zoning Compliance shall state specifically wherein the non-conforming use differs with the provisions of this Ordinance.

The Zoning Administrator may permit the occupancy of a building prior to the completion of all required work provided a bond or other assurance has been posted with the city recorder in an amount equal to the cost of completing said required work as determined by the Governing Body. The Zoning Administrator shall maintain a record of all Certificates of Zoning Compliance for a period of five (5) years and a copy shall be furnished upon request to any applicant.

At such time as any part shall have complied with the provisions relating to large-scale developments and to subdivisions as set forth in this Ordinance, the Planning Commission shall so certify and shall issue a certificate of compliance to the developer designating with particularity all lots or other tracts that are in compliance herewith and that are available for sale. It shall be unlawful for any developer or other person to sell or offer for sale or exchange either by deed, contract, or otherwise, any lot or tract of land within said large-scale developments or subdivision until such time as the developer shall have received a certificate of compliance with respect thereto.

02.1107 Zoning Administrator Appointed

The Charleston Town Council shall appoint the Zoning Administrator. Said Zoning Administrator shall be charged with the administration and enforcement of this Ordinance. The Charleston Town Council may also appoint other officers to assist in the administration and enforcement of this Ordinance.

02.1108 Powers and Duties of Zoning Administrator

It shall be the duty of the Zoning Administrator to inspect or cause to be inspected all buildings in the course of construction or repair. The Zoning Administrator shall enforce all of the provisions of this Ordinance, entering actions in the courts when necessary; and failure to do so shall not legalize any act in violation of such provisions.

Upon appeal to the Land Use Appeal Authority of any matters on which said Board is required to pass, the Zoning Administrator shall forthwith transmit all papers, records, and other pertinent data pertaining to the appeal to said Land Use Appeal Authority as required by the terms of this Ordinance. The Zoning Administrator shall also refer matters to the Planning Commission and governing body as set forth in this Ordinance.

CHARLESTON TOWN

02.1110: LAND USE APPEAL AND VARIANCE HEARING OFFICER:

A. Creation and Appointment: Pursuant to Utah Code section 10-9a-701 et seq., there is created in the Town an Appeal Authority. The Town Council shall appoint by resolution one or more Appeal and Variance Hearing Officers (also referred to in this section as "Hearing Officer") who will serve as the Appeal Authority for appeals of administrative land use decisions and variances. Notwithstanding the foregoing, any appeal and its related procedures from subdivision improvement plans as defined in Utah Code Section 10-9a-604.2 shall comply with Utah Code Sections 10-9a-604.2(8) and 10-9a-508(5)(d).

B. Authority and Jurisdiction: A Hearing Officer shall have the following powers:

1. Hear and Decide Appeals: Unless otherwise specifically provided in this title or title 10, "Subdivision and Development Code", of this Code, a Hearing Officer shall hear and decide all appeals alleging that there is error in any final written decision of the Zoning Administrator, Planning Director, Town Engineer, or Planning Commission administering or interpreting this title or in title 10, "Subdivision and Development Code", of this Code.

2. Authorize Variances: The Hearing Officer may authorize, upon appeal, variances from the terms of this Ordinance pertaining to area and width of lot, size of yards, and height and size of buildings where owing to special conditions, peculiar to the property, a literal enforcement of the provision of this Ordinance would result in a hardship which is unnecessary in carrying out the intent of this Ordinance. Any person or entity desiring a waiver or modification of the requirements of a land use ordinance as applied to a parcel of property that he owns, leases, or in which he holds some other beneficial interest may apply to the applicable appeal authority for a variance from the terms of the ordinance.

a. The Hearing Officer may grant a variance only if:

(i) literal enforcement of the ordinance would cause an unreasonable hardship for the applicant that is not necessary to carry out the general purpose of the land use ordinances.

(ii) there are special circumstances attached to the property that do not generally apply to other properties in the same zone;

(iii) granting the variance is essential to the enjoyment of a substantial property right possessed by other property in the same zone;

(iv) the variance will not substantially affect the general plan and will not be contrary to the public interest; and

(v) the spirit of the land use ordinance is observed and substantial justice done.

b. In determining whether or not enforcement of the land use ordinance would cause unreasonable hardship under Subsection 2. a., the Hearing Officer may not find an unreasonable hardship unless the alleged hardship:

i. is located on or associated with the property for which the variance is sought; and

ii. comes from circumstances peculiar to the property, not from conditions that are general to the neighborhood.

iii. In determining whether or not enforcement of the land use ordinance would cause unreasonable hardship under Subsection (2)(a), the Hearing Officer may not find an unreasonable hardship if the hardship is self-imposed or economic.

c. In determining whether or not there are special circumstances attached to the property under Subsection (2)(a), the Hearing Officer may find that special circumstances exist only if the special circumstances:

i. relate to the hardship complained of; and

CHARLESTON TOWN

- ii. deprive the property of privileges granted to other properties in the same zone.
- d. The applicant shall bear the burden of proving that all of the conditions justifying a variance have been met.
- e. Variances run with the land.
- f. The Hearing Officer may not grant a use variance.
- g. In granting a variance, the Hearing Officer may impose additional requirements on the applicant that will:
 - i. mitigate any harmful effects of the variance; or
 - ii. serve the purpose of the standard or requirement that is waived or modified.

3. Transitional Uses: Uses which are permitted on either portion of a lot, which lot is divided by a zone boundary line or which is contiguous with a zone boundary line, may be permitted to extend to the entire lot, but not more than one hundred (100) feet beyond the boundary line of such zone in which such use is permitted. Before a permit for such a use may be granted, however, the Hearing Officer must find that the comprehensive plan of zoning will be maintained and that a more harmonious mixing of uses will be achieved thereby.

4. Interpret Land Use Code and Land Use Map: It is the intent of this provision to provide a way whereby applicants who think that the Zoning Administrator is in error or does not interpret the provision of the Zoning Ordinance correctly to obtain a relief from such error in an expeditious without having to resort to the courts.

1. Duty to Interpret: The Hearing Officer shall hear and decide appeals where it is alleged by the appellant that there is error in any order, requirement, decision, or refusal made in the enforcement of his Ordinance.

2. Interpretation of the Land Use Map: The Hearing Officer shall also interpret the zone map and boundaries thereof in cases of dispute or disagreement.

5. Small Lots: Lots where a parcel of land at the time of the adoption of this Ordinance (circa 1973) is at least one and eight-tenths times as wide and one and eight-tenths times as large in area as required for a lot in the zone, the Hearing Officer may permit the division of a parcel into two lots, provided:

- a. Such division will not cause undue concentration of population;
- b. The characteristics of the zone in which the lot is located will be maintained; and
- c. In the opinion of the Hearing Officer, values in the area will be safeguarded adequately.

6. Reduce Off-street Parking Requirements: The Hearing Officer may approve substitute parking locations and may reduce the amount of off-street parking required provided:

- a. It can be shown that the time of use of the buildings or uses will be at different hours or days so that each use will have the amount of off-street parking available when the building or use is occupied;
- b. Sufficient off-street parking is readily available within the vicinity; and
- c. Where acquisition of land for such use is unnecessary in order to carry out the purposes of this Ordinance.

02.1111: APPEALS AND APPEAL PROCESS:

A. Parties Entitled to Appeal:

1. The Town, an applicant, or any other person or party adversely affected by a final written decision of the Zoning Administrator, Planning Director, Town Engineer, or Planning Commission administering or interpreting this title or title 10, "Subdivision and Development Code", of this Code may appeal the decision to a Hearing Officer.

2. If an appeal is regarding a landowner's property but the landowner is not the appellant or appellee, a Hearing Officer may determine the landowner's level of involvement in an appeal.

CHARLESTON TOWN

B. Time to File Appeal: A Hearing Officer may only consider appeals properly filed pursuant to this section within ten (10) days of the date the disputed final written decision was issued.

C. Application: All appeals are limited to the land use decisions on the record. "Record" means the land use application, public meeting/minutes, and any relevant public document held by the Town that specifically relates to the issue(s) on appeal. An appellant shall file an appeal in writing by submitting an online appeal application to the Town. A Hearing Officer may only consider an appeal if the appellant submitted a complete application within the time period provided in subsection B of this section. An appeal application is complete if it includes:

1. A completed application form provided by the Town.
2. Payment of applicable fees including those shown on the current year Town fee schedule.
3. A written statement that is no more than five (5) pages with one-inch (1") margins, 12-point Times New Roman font, single spaced, that concisely:
 - a. Explains the appellant's standing to appeal;
 - b. Identifies the alleged error that is grounds for the appeal; and
 - c. Provides reasons the appellant claims the applicable decision was made in error.
4. All records (e.g., land use application, staff reports, and meeting minutes). The records may be attached to the written statement as an exhibit and, if so, the exhibits shall not be counted against the statement's page limit.

D. Stay of Proceedings Pending Appeal: An appeal stays all proceedings, unless the officer or decision making body that made the decision being appealed certifies to a Hearing Officer after the notice of appeal is filed with the Town Clerk that, by reason of the facts stated in the certificate, the stay would in the officer's or decision making body's opinion cause imminent peril to life and property. In such case, proceedings shall not be stayed unless a Hearing Officer or the District Court grants a restraining order on application, notice, and due cause shown.

E. Notice of Hearing: After receiving an appeal application from the Town Clerk, a Hearing Officer shall fix a reasonable time and place for hearing the appeal during a public meeting. Thereafter, the Town Clerk shall publish an agenda at Town Hall and on the Town's website, give notice to the parties, and provide the appeal application to appellee.

F. Response and Representation: At least ten (10) days prior to the hearing, the appellee may submit to the Town Clerk a response to the appeal application that the Town Clerk shall give to a Hearing Officer and appellant. The response shall have the same restrictions listed in subsection C3 of this section. At the hearing, the parties may appear in person or by agent or attorney.

G. Hearing Officer: A Hearing Officer shall:

1. Act in a quasi-judicial manner and serve as the final arbiter of issues involving the interpretation or application of land use ordinances; and
2. May not entertain an appeal of a matter in which the Hearing Officer first acted as the Land Use Authority.

H. Hearing and Decision Procedures:

1. Minutes: A Hearing Officer shall cause minutes to be kept of all proceedings before him or her and shall keep record of all other official actions, including written decisions.

A Hearing Officer's minutes and official records shall be immediately filed with the Town Clerk as a public record and shall be retained according to applicable law.

2. Written Decision: A Hearing Officer shall file with the Town Clerk a written decision on each appeal that reverses or affirms, in whole or in part, the administrative decision being appealed.

- a. The written decision shall set forth the facts and law upon which the decision is made.
- b. If a Hearing Officer reverses any part of the administrative decision being appealed, the Hearing Officer shall remand the administrative decision to the officer or decision making body that made the decision for further proceedings consistent with the Hearing Officer's decision.

CHARLESTON TOWN

c. The Town Clerk shall notify the parties of a Hearing Officer's decision by mail within ten (10) days of the decision's effective date.

d. A decision of a Hearing Officer takes effect and is final on the date when the Hearing Officer issues a written decision.

3. Other Policies and Procedures: A Hearing Officer may formally adopt other policies and procedures that do not otherwise conflict with this section or other laws.

I. Scope of Review: The scope of review is limited to factual matters on the record. A Hearing Officer shall:

1. Determine whether the record on appeal includes substantial evidence for each essential finding of fact.

2. Receive no public comment, including witness testimony, and the parties may not present new evidence outside the record.

3. Determine the correctness of the interpretation and application of the plain meaning of the land use regulation.

J. Burden of Proof: The appellant has the burden of proving the appealed decision was made in error.

K. Judicial Review of Hearing Officer's Decision: The Town or any person adversely affected by any Hearing Officer's decision may file a petition for review of the decision with the District Court within thirty (30) days after the Hearing Officer's decision is final.

L. Stay of Decision: A Hearing Officer may stay his or her decision for thirty (30) days or until the District Court decides any appeal of the Hearing Officer's decision.

02.1121 Powers and Duties of the Planning Commission:

The Planning Commission shall have the following powers and duties with respect to this Ordinance:

1. The Planning Commission shall hear and decide requests for amendments to this Ordinance.
2. The Planning Commission may also act on its own initiative in considering and recommending amendments to this Ordinance. Before a favorable recommendation is given, however, it must be shown that:
 - a) The amendment will not be contrary to the land use map.
 - b) The amendment will not be contrary to the fulfillment of any provision of the general plan.
 - c) The amendment will not decrease nor adversely affect the health, safety, or general welfare of the public.
 - d) The amendment will more fully carry out the intent and purpose of this Ordinance.
 - e) That, balancing the interest of the petitioner with the interest of the public, both interests will be served better by adopting such an amendment.
 - f) In considering a request for an amendment to the Zoning Ordinance or Map, the Planning Commission may submit to the Town Council a recommendation for or against the request or it may recommend an alternate amendment.
3. To review, approve, disapprove, or approve subject to modifications, requests for permits to construct large-scale developments.

CHARLESTON TOWN

4. Any other duty imposed on the Planning Commission under the terms of this Ordinance.

The Planning Commission shall act as the Land Use Authority.

02.1122 Powers and Duties of the Municipality

The governing body may amend, change, or modify any provision of the Zoning Ordinance or Map provided they follow the procedure in 02.0704 (Amendments to Ordinance and Map) in this Zoning Ordinance.

02.1200 SEPARABILITY

This Ordinance and the various parts, sections, and clauses are hereby declared to be separable. If any part, section, paragraph, sentence, clause, or phrase is adjudged to be unconstitutional or invalid, it is hereby declared that the remainder of the Ordinance shall not be affected thereby. The Governing Body of Charleston Town, Utah, hereby declares that it would have passed this Ordinance on each part, section, paragraph, sentence, clause, or phrase thereof, irrespective of the fact that any one or more portions thereof be declared invalid.

02.1300 RESPONSIBILITY FOR VIOLATIONS

It shall be the duty of all architects, contractors, subcontractors, builders, and other persons having to do with the establishment of any use of land or the erection, altering, changing, or remodeling of any building or structure to make sure that a proper permit has been granted before work is begun on any project for which a permit is required. Any such architect, builder, contractor, or other person doing or performing any such work without a permit having been issued is in conflict with the requirements of this Ordinance and shall be deemed guilty of violation of this Ordinance in the same premises or the persons for whom the use is established, or for whom such buildings are erected or altered, and shall be subject to the penalties herein prescribed for violation.

02.1400 PENALTY

Any firm, corporation, person, or persons violating any of the provisions of this Ordinance shall be guilty of a class B misdemeanor. The Town Attorney may bring action before any competent court having jurisdiction to enjoin the continuation of any prohibited condition and impose a civil penalty of up to \$1,000 per day plus costs and reasonable attorney's fees.

02.1500 EACH DAY OF VIOLATION A SEPARATE VIOLATION

Each person, persons, firm or corporation found guilty of violations shall be deemed guilty of a separate offense for every day during which any violation of any provision of this Ordinance is committed, continued, or permitted by such person, persons, firm, or corporation, and shall be punished as provided in this Ordinance.

02.1600 CONFLICTING PROVISIONS REPEALED

All ordinances, resolutions, or parts thereof in conflict with the provisions of the Ordinance are hereby repealed insofar as they conflict with the provisions set forth in this Ordinance, provided, however, that any building or use of land or any construction thereon which was not authorized by or under the ordinances of the Town or which was illegal under such ordinances, shall remain unauthorized and illegal unless expressly authorized or permitted by the provisions of this Ordinance.

CHARLESTON TOWN

02.1700 EFFECTIVE DATE

In consideration of impending development, the Board of Trustees of the Town of Charleston, Utah, declares an emergency exists and it is necessary for the health, safety, peace, and general welfare of the Town and the inhabitants thereof that this Ordinance take effect immediately. This Ordinance shall therefore be enforced and take effect from and after passage by the Board of Trustees of the Town of Charleston and posted in three (3) public places in the Town, as required by law.